

On proximity and other distance parameters in planar graphs

Peter Dankelmann^{1,*}, Sonwabile Mafunda^{1,2}, Sufiyan Mallu^{1,†}

¹University of Johannesburg, South Africa

*pdankelmann@uj.ac.za

†sufiyanm@uj.ac.za

²Soka University of America, USA

smafunda@soka.edu

Received: 29 August 2025; Accepted: 10 June 2026

Published Online: 18 June 2026

This paper is dedicated to Professor Odile Favaron
on the occasion of her 88th birthday.

Abstract: Let G be a connected graph. The average distance of a vertex v of G is the arithmetic mean of the distances from v to all other vertices of G . The proximity and remoteness of G are defined as the minimum and maximum, respectively, of the average distances of the vertices of G .

It was shown by Aouchiche and Hansen [Proximity and remoteness in graphs: bounds and conjectures, Networks 58 no. 2 (2011)] that for a connected graph of order n , the difference between remoteness and proximity and the difference between radius and proximity are bounded from above by about $\frac{n}{4}$, and the difference between diameter and proximity is bounded from above by about $\frac{3}{4}n$.

In this paper, we show that all three bounds can be improved significantly for simple triangulations (i.e., triangulations), and for graphs of given connectivity.

We show that in simple triangulations the above bound on the difference between radius and proximity can be improved to about $\frac{1}{12}n$, and further to about $\frac{1}{16}n$ and $\frac{1}{20}n$ if the graphs is, in addition, 4-connected or 5-connected, respectively. Similar improvements are shown for simple quadrangulations (i.e., maximal bipartite planar graphs), and for maximal outerplanar graphs. We further show that the above bound on the difference between remoteness and proximity can be improved to about $\frac{1}{4\kappa}n$ if G is κ -connected. Finally, we improve the bound on the difference between diameter and proximity to about $\frac{3}{4\kappa}n$ if G is κ -connected. We present graphs that demonstrate that our bounds are either sharp, or sharp apart from an additive constant, even if restricted to planar graphs.

Keywords: remoteness, proximity, minimum status, planar graph, outerplanar graph, radius.

AMS Subject Classification: 05C12

* Corresponding Author

1. Introduction

In this paper we consider finite, connected graphs with no loops or multiple edges. In a connected graph G of order $n \geq 2$ with vertex set V , the average distance $\bar{\sigma}_G(v)$ of a vertex is defined to be the arithmetic mean of the distances from v to all other vertices of G , i.e., $\bar{\sigma}_G(v) = \frac{1}{n-1} \sum_{w \in V} d_G(v, w)$, where the distance $d_G(v, w)$ denotes the usual shortest path distance. The proximity $\pi(G)$ and remoteness $\rho(G)$ of G are defined as the minimum and maximum, respectively, of the average distances of the vertices of G , i.e.,

$$\pi(G) = \min_{v \in V} \bar{\sigma}_G(v), \quad \rho(G) = \max_{v \in V} \bar{\sigma}_G(v).$$

The terms proximity and remoteness were first used in a paper on automated comparison of graph invariants [3], and it has been widely studied as discussed below. However, the proximity of graphs and closely related concepts had been studied before under different names. Zelinka [34] studied the *vertex deviation*, defined as $\frac{\sigma_G(v)}{n}$, where $\sigma_G(v)$ denotes the sum of the distances between v and all other vertices, and n is the number of vertices. Also the name *minimum status*, defined as $\min_{v \in V(G)} \sigma(v)$ has been used (see, for example, [22]).

Proximity and remoteness in a network indicate how central the most central vertex or the least central vertex, respectively, is in the network. This is relevant, for example, when identifying the most influential individuals on Facebook. It is also applicable in facility location problems, where, for instance, in a town, we may wish to determine an optimal location for a desirable facility (such as a supermarket) or an undesirable facility (such as a garbage dumping facility) (see [11, 17, 18]).

Bounds on proximity and remoteness in terms of order only were given by Zelinka [34] and later, independently, by Auouchiche and Hansen [4].

Theorem 1. (Zelinka [34], Auouchiche, Hansen [4])

(a) Let G be a connected graph of order $n \geq 2$. Then

$$\pi(G) \leq \begin{cases} \frac{n+1}{4} & \text{if } n \text{ is odd,} \\ \frac{n+1}{4} + \frac{1}{4(n-1)} & \text{if } n \text{ is even,} \end{cases}$$

with equality if and only if G is either a path or a cycle.

(b) Let G be a connected graph of order $n \geq 2$. Then

$$\rho(G) \leq \frac{n}{2},$$

with equality if and only if G is a path.

Relations between proximity and other graph parameters have been studied, for example girth [5], maximum degree see [15, 23] clique number see [20], matching number

and domination number [22, 27], radius [29] and distance eigenvalues [24]. The proximity of trees with no vertex of degree 2 was investigated in [8]. For a recent survey on proximity and remoteness in graphs see [6]. Recently, directed versions of proximity and remoteness were introduced by Ai, Gerke, Gutin and Mafunda [1]. It was shown in [11] that the bounds in Theorem 1 can be improved by a factor of about $\frac{3}{\delta+1}$ for graphs of minimum degree δ . In [13], these bounds were improved further for graphs not containing cycles of length 3 or 4.

Relatively few results are known concerning proximity and remoteness in planar graphs. Che and Collins [7] established a sharp upper bound on the remoteness of a triangulation of a given order. Subsequently, in 2021, Czabarka et al. [9] provided sharp upper bounds on the remoteness of k -connected triangulations for $k \in \{4, 5\}$ and k -connected quadrangulations for $k \in \{2, 3\}$. Their work was further extended in 2022 when Czabarka et al. [10] derived bounds on proximity for k -connected triangulations with $k \in \{3, 4, 5\}$ and k -connected quadrangulations for $k \in \{2, 3\}$. While the bounds on remoteness are sharp, the proximity bounds are sharp only up to an additive constant. These results motivate the study of proximity and remoteness in restricted classes of planar graphs and naturally raise the question of how these parameters compare with classical distance parameters such as the diameter and the radius.

Theorem 2. (Czabarka, Dankelmann, Olsen, Székely [9, 10])

(a) If G is a simple triangulation of order n , then

$$\rho(G) \leq \frac{n+2}{6} + \varepsilon_n, \quad \pi(G) \leq \frac{n+19}{12} + \frac{25}{3(n-1)},$$

where $\varepsilon_n = 0$ if $n \equiv 1 \pmod{3}$, and $\varepsilon_n = \frac{1}{3(n-1)}$ otherwise.

(b) If G is a 4-connected simple triangulation of order n , then

$$\rho(G) \leq \frac{n+3}{8} + \varepsilon_n, \quad \pi(G) \leq \frac{n+35}{16} + \frac{91}{4(n-1)},$$

where $\varepsilon_n = 0$ if $n \equiv 1 \pmod{4}$, $\varepsilon_n = \frac{1}{2(n-1)}$ if $n \equiv 3 \pmod{4}$, and $\varepsilon_n = \frac{3}{8(n-1)}$ otherwise.

(c) If G is a 5-connected simple triangulation of order n , then

$$\rho(G) \leq \frac{n+4}{10} + \varepsilon_n, \quad \pi(G) \leq \frac{n+57}{20} + \frac{393}{10(n-1)},$$

where $\varepsilon_n = -\frac{3}{5(n-1)}$ if $n \equiv 0 \pmod{5}$, $\varepsilon_n = -\frac{1}{n-1}$ if $n \equiv 1 \pmod{5}$, $\varepsilon_n = \frac{2}{5(n-1)}$ if $n \equiv 2 \pmod{5}$, and $\varepsilon_n = -\frac{2}{5(n-1)}$ otherwise.

In (a)-(c), the bounds on remoteness are sharp, and the bounds on proximity are sharp apart from an additive constant.

Bounds on proximity and remoteness in outerplanar graphs in terms of order and maximum face length were given in [16].

It is natural to ask how large the differences between proximity, remoteness, and other distance parameters can be. This question was answered for the difference between proximity and remoteness by Aouchiche and Hansen [4], who obtained the following sharp bound.

Theorem 3. (Aouchiche, Hansen [4])

Let G be a connected graph of order $n \geq 3$. Then

$$\rho(G) - \pi(G) \leq \begin{cases} \frac{n-1}{4} & \text{if } n \text{ is odd,} \\ \frac{n-1}{4} - \frac{1}{4(n-1)} & \text{if } n \text{ is even.} \end{cases}$$

Equality holds if and only if G is a graph constructed by joining an endpoint of a path $P_{\lceil \frac{n}{2} \rceil}$ with any vertex of a connected graph H on $\lfloor \frac{n}{2} \rfloor + 1$ vertices.

Aouchiche and Hansen [4] determined also the maximum differences between diameter and proximity, and between radius and proximity in a connected graph.

Theorem 4. (Aouchiche, Hansen [4])

Let G be a connected graph of order $n \geq 3$. Then

$$\text{diam}(G) - \pi(G) \leq \begin{cases} \frac{3n-5}{4} & \text{if } n \text{ is odd,} \\ \frac{3n-5}{4} - \frac{1}{4n-4} & \text{if } n \text{ is even.} \end{cases}$$

Equality holds if and only if G is a path.

Theorem 5. (Aouchiche, Hansen [4])

Let G be a connected graph of order $n \geq 3$. Then

$$\text{rad}(G) - \pi(G) \leq \begin{cases} \frac{n-1}{4} - \frac{1}{n-1} & \text{if } n \text{ is odd,} \\ \frac{n-1}{4} - \frac{1}{4n-4} & \text{if } n \text{ is even.} \end{cases}$$

and this bound is sharp.

The extremal graphs maximising the differences $\rho(G) - \pi(G)$ in Theorem 3 and $\text{diam}(G) - \pi(G)$ in Theorem 4 contain many vertices of degree 2. Hence it is natural to expect that this bound can be improved for graphs in which the vertex degrees are larger. For graphs of given minimum degree δ , the bounds in Theorems 3 to 5 were improved by a factor of about $\frac{3}{\delta+1}$ in [12], and for further improved bounds see [14]. Also other differences between distance parameters were considered in the literature, for example between radius and remoteness [19], between average eccentricity (defined as the arithmetic mean of the eccentricities of all vertices) and proximity [25], between remoteness and radius [33], between remoteness and average distance (defined as

the arithmetic mean of the distances between all pairs of distinct vertices) [33] and between proximity and average distance [30].

The aim of this paper is to improve the bounds on the differences between proximity and the three distance parameters remoteness, diameter and radius in Theorems 3, 4 and 5 for simple triangulation and maximal outerplanar graphs and for graphs of given connectivity. We show that for triangulations the bound in Theorem 5 can be improved to about $\frac{1}{12}n$, with further improvements to about $\frac{1}{16}n$ and $\frac{1}{20}n$ for 4-connected and 5-connected maximal planar graphs, respectively. We also improve the bounds in Theorems 3 and 4 by a factor of $\frac{1}{\kappa}$ for κ -connected graphs.

This paper is organised as follows. In Section 2, we define the main terms and notation used in this paper. Some results on planar and outerplanar graphs that are used in the sections that follow are presented in Section 3. In Section 4 we prove bounds on the difference between radius and proximity in simple triangulations and simple quadrangulations of given connectivity, and for maximal outerplanar graphs. The difference between remoteness and proximity in graphs of given connectivity is considered in Section 5, and the last section, Section 6, presents bounds on the difference between diameter and proximity in graphs of given connectivity.

2. Terminology and notation

We use the following notation. Let G be a connected graph and let u and v be vertices of G . We denote by $V(G)$ and $E(G)$ the *vertex set* and *edge set*, respectively. The *order* n of a graph is the cardinality of the vertex set.

The *distance* $d_G(u, v)$ between u and v is the minimum number of edges on a shortest path from u to v . The *eccentricity* $\text{ecc}_G(v)$ of a vertex v in a graph G is the distance from v to a vertex farthest from v . The *diameter* is the largest of all eccentricities of vertices of G , and the *radius* is the smallest of all eccentricities of vertices of G , they are denoted by $\text{diam}(G)$ and $\text{rad}(G)$, respectively. For a vertex v and a set X of vertices, we denote the sum $\sum_{x \in X} d_G(v, x)$ by $\sigma(v|X)$. The *total distance* of a vertex v is defined by $\sigma(v) = \sum_{w \in V} d(v, w)$.

Let $i \in \mathbb{Z}$. Then $N_i(v)$, $N_{\leq i}(v)$ and $N_{> i}(v)$ denote the set of all vertices of G at distance exactly, at most and at least i , respectively, from v . We write $n_i(v)$ for $|N_i(v)|$. Clearly, $n_i(v) > 0$ if and only if $0 \leq i \leq \text{ecc}_G(v)$. The *neighbourhood* $N(v)$ of v is the set of vertices adjacent to v , i.e., $N_1(v)$.

We denote the *complete graph* of order n by K_n , the *cycle* of order n by C_n , and the *edgeless graph* of order n by $\overline{K_n}$. If G_1, G_2, \dots, G_k are graphs, then the sequential sum $G_1 + G_2 + \dots + G_k$ is the graph obtained from the disjoint union of G_1, G_2, \dots, G_k by adding an edge between each vertex of G_i and each vertex of G_{i+1} for $i = 1, 2, \dots, k-1$. By $[G_1 + G_2 + \dots + G_k]^k$ we mean k repetitions of the pattern $G_1 + G_2 + \dots + G_k$. A graph G is *planar* if it can be embedded in the plane with no edges crossing. A planar graph is *outerplanar* if it can be embedded in the plane so that no edges cross and every vertex is on the boundary of the outer face. A *maximal* (outer-)planar graph is an (outer-)planar graph that is no longer (outer-)planar after adding any

edge. Similarly, a *maximal bipartite planar graph* is a graph that is planar and bipartite, but after adding any edge it is no longer planar or bipartite. By a triangulation (respectively, a quadrangulation), also called a simple triangulation (respectively, a simple quadrangulation), we mean a maximal planar graph (respectively, a maximal bipartite planar graph). Since every 3-connected planar graph [32], every quadrangulation and every 2-connected outerplanar graph has a unique embedding in the plane [21], we often assume that the graph has been embedded in the plane, and we use the terms (*outer-*)planar and (*outer-*)plane interchangeably for such graphs.

3. Preliminary results on (outer-)planar graphs

In this section we present some results which will be used in the sections that follow. Let vertex v be fixed, then we say a vertex $u \in N_i(v)$ is **active** if u has a neighbour in $N_{i+1}(v)$. The set of active vertices within $N_i(v)$ is denoted by $A_i(v)$. For $1 \leq i \leq \text{ecc}(v) - 1$, we define \hat{H}_i to be the graph with vertex set A_i , where two vertices are adjacent if and only if they share a face in G .

Lemma 1. ([2]) *Let G be a planar graph, let $v \in V(G)$ and $1 \leq i \leq \text{ecc}(v) - 1$. Let $A_i(v)$ and \hat{H}_i be as defined above.*

- (a) *If G is 3-connected and u is a vertex in \hat{H}_i , then u has two distinct neighbours $v, w \in A_i(v) - \{u\}$ in \hat{H}_i .*
- (b) *If G is 4-connected and u, w, x are three distinct vertices in \hat{H}_i , then at least one of them has a neighbour in $A_i(v) - \{u, w, x\}$ in \hat{H}_i .*
- (c) *If G is 5-connected and u is a vertex in \hat{H}_i , then u has two neighbours, w and x , in \hat{H}_i such that w and x share no common neighbour in \hat{H}_i other than u .*

Lemma 2. ([10]) *Let G be a quadrangulation, v a vertex of G , and let $1 \leq i \leq \text{ecc}(v) - 1$. For every active vertex $w \in N_i(v)$, there exists another active vertex $w' \in N_i(v)$ such that w and w' share a common face of G .*

We use the following result due to Leydold and Stadler [21] in the proof of the following lemma. An outerplanar graph is Hamiltonian if and only if it is 2-connected, and in this case the Hamiltonian cycle is unique. We now prove a result similar to Lemma 2 for outerplanar graphs. Its proof uses a similar approach as Lemma 1 in [2].

Lemma 3. *Let G be a 2-connected outerplanar graph, v a vertex of G , and $i \in \{1, 2, \dots, \text{ecc}(v) - 1\}$. For every active vertex $u \in N_i(v)$, there exist another active vertex $u' \in N_i(v)$ such that u and u' share a face in G which is distinct from the outer face.*

Proof. Let $u \in N_i(v)$ be an arbitrary active vertex. Label the neighbours of u as x_0, x_1, \dots, x_t such that the edges ux_i appear in, say, clockwise order, and edges ux_0 and ux_t are on the Hamiltonian cycle C . Denote the face containing u , x_j and x_{j+1}

by f_j for $j \in \{0, 1, \dots, t - 1\}$. Let P_i be the (x_i, x_{i+1}) -path of the vertices on the boundary of f_i except u in clockwise order. Let x_p be a neighbour of u in N_{i-1} and let x_q be a neighbor of u in N_{i+1} . We may assume that $p < q$. Let W be a (x_p, x_q) -walk that traverses the vertices of P_p then $P_{p+1}, P_{p+2}, \dots, P_{q-1}$. Let z be the first vertex of W in N_{i+1} and let u' be its predecessor. Then u' is in N_i , and since it is adjacent to z , u' is active. Moreover, u' shares a face with u since it is on W . The lemma follows. \square

Also the following result, which appears to be folklore, will be used in Section 4.

Proposition 1. *Let G be a connected graph of order n . Then*

$$\text{rad}(G) \leq \lfloor \frac{n}{2} \rfloor.$$

4. Radius vs proximity

In this section we prove upper bounds on the difference between radius and proximity in triangulations and quadrangulations of given connectivity, and in maximal outerplanar graphs.

Theorem 6. *Let G be a triangulation of order $n \geq 4$. Then*

$$\text{rad}(G) - \pi(G) \leq \frac{n + 1}{12} + \frac{4}{3} + \frac{27}{4(n - 1)}.$$

Proof. Assume G is a triangulation of order $n \geq 4$. Let v_0 be a median vertex of G and let $R := \text{ecc}(v_0)$, and let $r := \text{rad}(G)$. Recall that $N_i(v_0)$ is the set of vertices at distance i from v_0 , for $i \in \{0, 1, \dots, R\}$ and let $A_i := A_i(v_0)$ be the set of active vertices in $N_i(v_0)$. We show that

$$\sigma(v_0) \geq 3r^2 - 9r. \tag{4.1}$$

We consider two cases, depending on whether R is much larger than r or not.

CASE 1: $R \geq \frac{1}{2}(3r - 5)$.

Since G is a triangulation, it is 3-connected. Hence, we have that $|N_i(v_0)| \geq 3$ for $i \in \{1, 2, \dots, R - 1\}$, and thus

$$\sigma(v_0) = \sum_{i=1}^R |N_i(v_0)| i > \sum_{i=1}^{R-1} 3i = \frac{3}{2}(R^2 - R).$$

Now the term $\frac{3}{2}(R^2 - R)$ is increasing in R . Substituting $\frac{1}{2}(3r - 5)$ for R yields the inequality

$$\sigma(v_0) \geq 3 \left(\frac{9}{8}r^2 - \frac{9}{2}r + \frac{35}{8} \right) > 3r^2 - 9r,$$

and (4.1) follows in Case 1.

CASE 2: $R \leq \frac{1}{2}(3r - 6)$.

We first prove the following claim.

Claim 1. If $R - r + 3 \leq i \leq 2r - R - 3$, then $|A_i| \geq 6$.

Suppose to the contrary that there exist some $j \in \{R - r + 3, \dots, 2r - R - 3\}$ such that $|A_j| \leq 5$. It follows from Lemma 1 (a) that each component of the graph \hat{H}_j has at least three vertices, so \hat{H}_j is connected. By Proposition 1 we have $\text{rad}(\hat{H}_j) \leq \lfloor \frac{|A_j|}{2} \rfloor \leq \lfloor \frac{5}{2} \rfloor = 2$. Let $x_j \in A_j$ be a vertex of eccentricity at most 2 in \hat{H}_j . Since two vertices of G that are on the boundary of the same face are adjacent in G , we have $d_G(x_j, w_j) \leq 2$ for all $w_j \in A_j$. Let $P : v_0 = x_0, x_1, \dots, x_j$ be a shortest (x_0, x_j) -path in G . Consider x_{R-r+3} . We show that $\text{ecc}(x_{R-r+3}) < r$, leading to a contradiction, thereby establishing Claim 1.

Since G has radius r , there exists a vertex v of G with $d(x_{R-r+3}, v) \geq r$. Then $v \in N_{\geq j}(v_0)$ or $v \in N_{\leq j-1}(v_0)$. We now first consider the case $v \in N_{\geq j}(v_0)$. Let w_j be the vertex of N_j belonging to a shortest (v_0, v) -path. Then $w_j \in A_j$, and so

$$\begin{aligned} d(x_{R-r+3}, v) &\leq d(x_{R-r+3}, x_j) + d(x_j, w_j) + d(w_j, v) \\ &\leq (j - R + r - 3) + 2 + (R - j) \\ &= r - 1, \end{aligned}$$

a contradiction. Now consider the case $v \in N_{\leq j-1}$. Then

$$\begin{aligned} d(x_{R-r+3}, v) &\leq d(x_{R-r+3}, v_0) + d(v_0, v) \\ &\leq R - r + 3 + j - 1 \\ &\leq R - r + 3 + 2r - R - 4 \\ &= r - 1, \end{aligned}$$

again a contradiction, which completes the proof of Claim 1.

Now $|N_i(v_0)| \geq 3$ for all $i \in \{1, 2, \dots, R\}$ since G is 3-connected, and $|N_i(v_0)| \geq |A_i(v_0)| \geq 6$ for $i = \{R - r + 3, R - r + 4, \dots, 2r - R - 3\}$. Hence

$$\begin{aligned} \sigma(v_0) &> \sum_{i=1}^{R-1} |N_i(v_0)| i \\ &\geq 3 \sum_{i=1}^{R-1} i + 3 \sum_{i=R-r+3}^{2r-R-3} i \\ &= 3 \left(\frac{R^2 - R}{2} + \frac{3r^2 - 2Rr - 5r}{2} \right). \end{aligned}$$

It is easy to verify that the derivative with respect to R of the right hand side of the above inequality equals $3(R - r) - \frac{3}{2}$, which is positive for $R \geq r + 1$. Hence the right

hand side above is minimised, subject to $R \in \mathbb{N}$ and $R \geq r$, if $R = r$. Substituting this value yields

$$\sigma(v_0) \geq 3r^2 - 9r.$$

Hence (4.1) holds also in Case 2.

From (4.1) we obtain the following lower bound on the proximity.

$$\pi(G) = \frac{\sigma(v_0)}{n-1} \geq \frac{1}{n-1} (3r^2 - 9r).$$

Thus,

$$\text{rad}(G) - \pi(G) \leq r - \frac{1}{n-1} (3r^2 - 9r).$$

Simple elementary calculus shows that for constant n , the right hand side of the above inequality is maximised for $r = \frac{n+8}{6}$. Substituting this value of r into the above inequality yields, after simplification, that

$$\text{rad}(G) - \pi(G) \leq \frac{n+17}{12} + \frac{27}{4(n-1)},$$

hereby completing the proof of the theorem. □

The following example shows that the bound in Theorem 6 is sharp apart from an additive constant.

Example 1. Let $n \geq 5$ with $n \equiv 5 \pmod{6}$ and let $k = \frac{n-2}{3}$. We define the graph T_n as follows. Let G_0 be the graph consisting of the single vertex b_0 . For each $i \in \{1, 2, \dots, k\}$, let G_i be a copy of the cycle C_3 with vertices a_i, b_i, c_i . Let G_{k+1} be the graph consisting of a single vertex b_{k+1} . The graph T_n is obtained from the disjoint union of the graphs $G_0, G_1, \dots, G_k, G_{k+1}$ by adding edges as follows: the vertex b_0 is adjacent to a_1, b_1 , and c_1 , for each $i \in \{1, 2, \dots, k-1\}$ the edges $a_i a_{i+1}$, $b_i b_{i+1}$, $c_i c_{i+1}$ and $c_i a_{i+1}$ are added, for each $i \in \{1, 2, \dots, \frac{k-1}{2}\}$ the edges $a_i b_{i+1}$ and $c_i b_{i+1}$ are added, for each $i \in \{\frac{k+1}{2}, \frac{k+1}{2} + 1, \dots, k-1\}$ the edges $b_i a_{i+1}$, and $b_i c_{i+1}$ are added, and finally, the edges $b_0 a_1, b_0 b_1, b_0 c_1$ and $a_k b_{k+1}, b_k b_{k+1}, c_k b_{k+1}$ are added. (See Figure 1 for a sketch.)

Clearly, T_n is a triangulation of order $n = 3k + 2$. It is easy to verify that $\text{rad}(T_n) = \frac{n+1}{6}$, $\pi(T_n) = \bar{\sigma}(b_{(k+1)/2}) = \frac{n+1}{12} + \frac{2}{n-1}$. Hence $\text{rad}(T_n) - \pi(T_n) = \frac{n+1}{12} - \frac{2}{n-1}$, which differs from the bound in Theorem 6 by $\frac{4}{3} + o(n)$.

For later use we note that $\text{diam}(T_n) = \frac{n+1}{3}$ and $\rho(T_n) = \bar{\sigma}(b_0) = \frac{n+2}{6} + \frac{1}{3(n-1)}$.

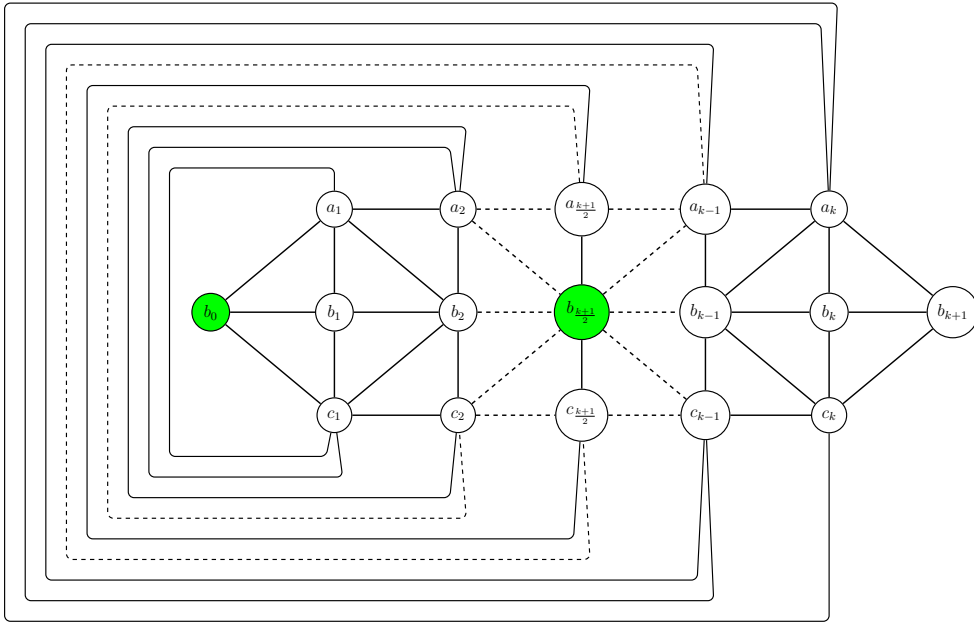

Figure 1. The triangulation T_n .

Theorem 7. Let G be a triangulation of order $n \geq 6$.

(a) If G is 4-connected, then

$$\text{rad}(G) - \pi(G) \leq \frac{n + 31}{16} + \frac{16}{n - 1}.$$

(b) If G is 5-connected, then

$$\text{rad}(G) - \pi(G) \leq \frac{n + 49}{20} + \frac{125}{4(n - 1)}.$$

Proof. Both proofs follow the lines of the proof of Theorem 6, so we give only the main steps. The detailed proof can be found in [26]. Let v_0 , $N_i(v_0)$, A_i , R and r be as in the proof of Theorem 6.

(a) Since G is 4-connected, we have $|N_i(v_0)| \geq 4$ for $i = 1, 2, \dots, R - 1$. Similar to (4.1) we prove that

$$\sigma(v_0) \geq 4r^2 - 16r, \tag{4.2}$$

by considering the two cases $R \geq \frac{1}{2}(3r - 7)$ and $R \leq \frac{1}{2}(3r - 8)$. In the proof of the latter case, we show, with the same arguments, a slightly altered version of Claim 1 in Theorem 6, which states that $|A_i| \geq 8$ holds for all i with $R - r + 4 \leq i \leq 2r - R - 4$. It follows from (4.2) that the difference $\text{rad}(G) - \pi(G)$ is bounded from above by

$r - \frac{1}{n-1}(4r^2 - 16r)$, which is maximised for $r = \frac{n+15}{8}$. Substituting this value yields Theorem 7(a).

(b) Since G is 5-connected, we have $|N_i(v_0)| \geq 5$ for $i = 1, 2, \dots, R - 1$. Similar to (4.1) we prove that

$$\sigma(v_0) \geq 5r^2 - 20r, \tag{4.3}$$

by considering the two cases $R \geq \frac{1}{2}(3r - 9)$ and $R \leq \frac{1}{2}(3r - 10)$. In the proof of the latter case, we show, with the same arguments, a slightly altered version of Claim 1 in Theorem 6, which states that $|A_i| \geq 10$ holds for all i with $R - r + 5 \leq i \leq 2r - R - 5$. It follows from (4.2) that the difference $\text{rad}(G) - \pi(G)$ is bounded from above by $r - \frac{1}{n-1}(5r^2 - 20r)$, which is maximised for $r = \frac{n+24}{10}$. Substituting this value yields Theorem 7(b). \square

Also the bounds in Theorem 7(a) and (b) are sharp apart from an additive constant. This is shown by constructing 4-connected triangulations (5-connected triangulations) in a way similar to Example 1, the main difference being that the C_3 in Example 1 are replaced by C_4 (C_5). We omit the details.

In a way similar to Theorem 6 we obtain bounds on the difference between radius and proximity for quadrangulations. Applying Lemma 2 and using analogous arguments as Theorem 6 we derive the following bound.

Theorem 8. (a) *If G is a quadrangulation of order n , then*

$$\text{rad}(G) - \pi(G) \leq \frac{n + 11}{8} + \frac{9}{2(n - 1)}.$$

(b) *If G is a 3-connected quadrangulation of order n , then*

$$\text{rad}(G) - \pi(G) \leq \frac{n + 17}{12} + \frac{27}{4(n - 1)}.$$

Proof. Let $v_0, N_i(v_0), A_i, R$ and r be as in the proof of Theorem 6.

(a) We show that

$$\sigma(v_0) \geq 2r^2 - 6r. \tag{4.4}$$

We now consider two cases depending on whether R is much larger than r or not.

CASE 1: $R \geq \frac{1}{2}(3r - 5)$.

Since every quadrangulation is 2-connected, we have that $|N_i(v_0)| \geq 2$ for $i \in \{0, 1, \dots, R - 1\}$, and thus

$$\sigma(v_0) = \sum_{i=1}^R |N_i(v_0)| i > \sum_{i=1}^{R-1} 2i = R^2 - R.$$

Now the term $R^2 - R$ is increasing in R . Hence by the defining condition of this case,

$$\sigma(v_0) \geq \frac{9}{4}r^2 - 9r + \frac{35}{4} > 2r^2 - 6r,$$

thus (4.4) follows in Case 1.

CASE 2: $R \leq \frac{1}{2}(3r - 6)$.

We first prove the following claim in this case.

Claim 1. If $R - r + 3 \leq i \leq 2r - R - 3$, then $|A_i| \geq 4$.

Suppose to the contrary that there exist some $j \in \{R - r + 3, \dots, 2r - R - 3\}$ such that $|A_j| \leq 3$. Then it follows from Lemma 2 that every component of the graph \hat{H}_j has at least two vertices, hence \hat{H}_j is connected. By Proposition 1 we have $\text{rad}(\hat{H}_j) \leq 1$. Hence there is a vertex $x_j \in A_j$ which shares a face with all other vertices of A_j , and thus has distance at most 2 from all vertices in A_j . Let $P : v_0 = x_0, x_1, \dots, x_j$ be a shortest (x_0, x_j) -path in G . Consider x_{R-r+3} . The same arguments as in the proof of Claim 1, Theorem 6 yield the contradiction $\text{ecc}(x_{R-r+3}) < r$, thereby establishing Claim 1.

By Claim 1 we have

$$\sigma(v_0) \geq 2 \left(\sum_{i=1}^{R-1} i + \sum_{i=R-r+3}^{2r-R-3} i \right) = R^2 - R + 3r^2 - 2Rr - 5r.$$

The remainder of the proof is almost identical to the corresponding part of the proof of Theorem 6, hence we omit it.

(b) Since G is 3-connected, we have $|N_i(v_0)| \geq 3$ for $i = 1, 2, \dots, R - 1$. Similar to (4.1) we prove that

$$\sigma(v_0) \geq 3r^2 - 15r, \tag{4.5}$$

by considering the two cases $R \geq \frac{3}{2}(r - 3)$ and $R \leq \frac{3}{2}r - 5$. In the proof of the latter case, we make use of Lemma 1(a) and show, with the same arguments, a slightly altered version of Claim 1 in Theorem 6, which states that $|A_i| \geq 6$ holds for all i with $R - r + 5 \leq i \leq 2r - R - 5$.

It follows from (4.5) that the difference $\text{rad}(G) - \pi(G)$ is bounded from above by $r - \frac{1}{n-1}(3r^2 - 15r)$, which is maximised for $r = \frac{n+14}{6}$. Substituting this value yields Theorem 8(b). □

The bound in Theorem 8(a) is sharp apart from an additive constant. This is shown by the following example.

Example 2. Given $n \in \mathbb{N}$ with $n \geq 4$, $n \equiv 0 \pmod{4}$. Let $k = \frac{n-2}{4}$. We define the graph Q_n as follows.

$$Q_n = K_1 + \overline{[K_2]}^k + K_1.$$

See Figure 2 for a sketch of Q_n . Clearly, Q_n is a quadrangulation of order $n = 2k + 2$. It is easy to verify that $\text{rad}(Q_n) = \frac{n}{4}$ and $\pi(Q_n) = \overline{\sigma}(b_{(k+1)/2}) = \frac{n+17}{8} + \frac{17}{8(n-1)}$. Hence

$\text{rad}(Q_n) - \pi(Q_n) = \frac{n-17}{8} - \frac{17}{8(n-1)}$, which differs from the bound in Theorem 8(a) by $\frac{17}{4} + o(n)$. For later use we note that $\text{diam}(Q_n) = \frac{n}{2}$ and $\rho(Q_n) = \bar{\sigma}(b_0) = \frac{n+1}{4} + \frac{1}{4(n-1)}$.

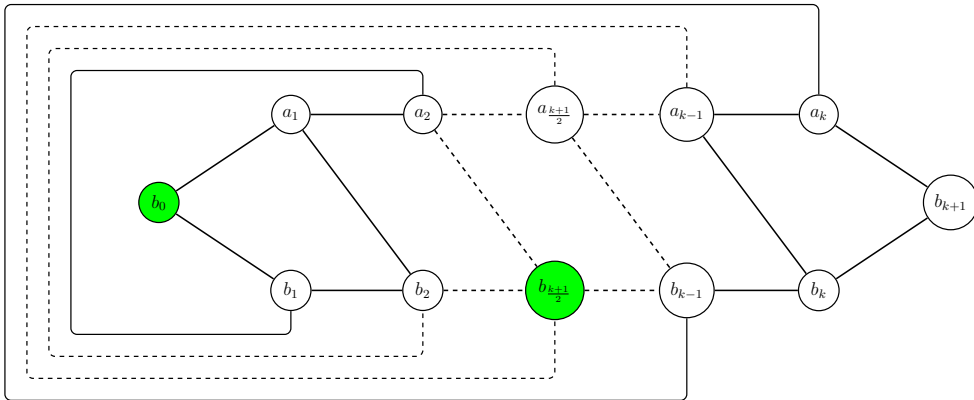

Figure 2. The quadrangulation Q_n .

Also the bounds in Theorem 8(b) is sharp apart from an additive constant. This is shown by constructing 3-connected quadrangulations in a way similar to Example 2. We omit the details.

We conclude this section with a bound for maximal outerplanar graphs.

Theorem 9. *Let G be a maximal outerplanar graph of order n . Then*

$$\text{rad}(G) - \pi(G) \leq \frac{n + 7}{8} + \frac{2}{n - 1}.$$

Proof. The proof follows the lines of the proof of Theorem 6, so we give only the main steps. The detailed proof can be found in [26]. Let $v_0, N_i(v_0), A_i, R$ and r be as in the proof of Theorem 6.

Since every maximal outerplanar graph is 2-connected, we have $|N_i(v_0)| \geq 2$ for $i = 1, 2, \dots, R - 1$. Similar to (4.1) we prove that

$$\sigma(v_0) \geq 2r^2 - 4r, \tag{4.6}$$

by considering the two cases $R \geq \frac{1}{2}(3r - 3)$ and $R \leq \frac{1}{2}(3r - 4)$. In the proof of the latter case, we make use of Lemma 3 and show, with the same arguments, a slightly altered version of Claim 1 in Theorem 6, which states that $|A_i| \geq 4$ holds for all i with $R - r + 2 \leq i \leq 2r - R - 2$.

It follows from (4.6) that the difference $\text{rad}(G) - \pi(G)$ is bounded from above by $r - \frac{1}{n-1}(2r^2 - 4r)$, which is maximised for $r = \frac{n+3}{4}$. Substituting this value yields Theorem 9. □

The bound in Theorem 9 is sharp apart from an additive constant, as demonstrated by the following example.

Example 3. Let $n \geq 4$ with $n \equiv 0 \pmod{4}$ and let $k = \frac{n-2}{2}$. We define the graph MOP_n as follows. Let G_0 be a single-vertex graph with vertex b_0 . For each $i \in \{1, 2, \dots, k\}$ let G_i be a copy of the path P_2 with vertices a_i and b_i . Let G_{k+1} be a single-vertex graph with vertex b_{k+1} . The graph MOP_n is obtained from the disjoint union of $G_0, G_1, \dots, G_k, G_{k+1}$ by adding edges as follows: vertex b_0 is connected to a_1 and b_1 , for each $i \in \{1, 2, \dots, k-1\}$ the edges $a_i a_{i+1}$ and $b_i b_{i+1}$ are added, for each $i \in \{1, 2, \dots, \frac{k-1}{2}\}$ the edge $a_i b_{i+1}$ is added, for each $i \in \{\frac{k+1}{2}, \dots, k-1\}$ the edge $b_i a_{i+1}$ is added, and finally, the edges $a_k b_{k+1}$ and $b_k b_{k+1}$ are added. See Figure 3 below for a sketch.)

Clearly, MOP_n is a maximal outerplanar graph of order $n = 2k + 2$. It is easy to verify that $\text{rad}(MOP_n) = \frac{n}{4}$ and $\pi(MOP_n) = \bar{\sigma}(b_{(k+1)/2}) = \frac{n+1}{8} + \frac{9}{8(n-1)}$. Hence $\text{rad}(MOP_n) - \pi(MOP_n) = \frac{n-1}{8} - \frac{9}{8(n-1)}$, which differs from the bound in Theorem 9 by $1 + o(n)$. For later use we note that $\text{diam}(MOP_n) = \frac{n}{2}$ and $\rho(MOP_n) = \bar{\sigma}(b_0) = \frac{n+1}{4} + \frac{1}{4(n-1)}$.

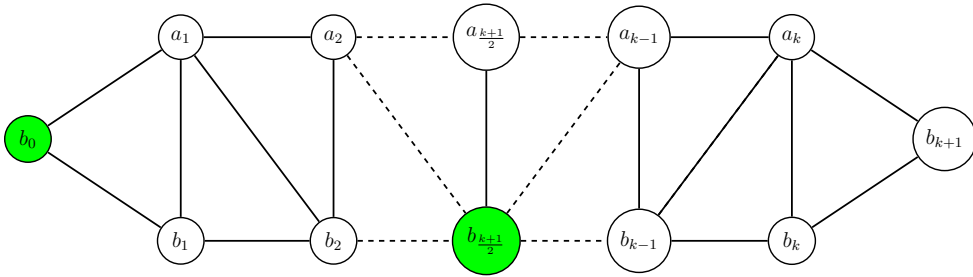

Figure 3. The maximal outerplanar graph MOP_n .

5. Remoteness vs proximity

In this section, we prove upper bounds on the difference between remoteness and proximity in graphs. Our bounds hold not only for triangulations of given connectivity, but for (not necessarily planar) graphs of given order and connectivity. We also give examples to demonstrate that our bounds are sharp, even if restricted to triangulations, quadrangulations or maximal outerplanar graphs.

Theorem 10. Let $n, \kappa \in \mathbb{N}$ with $\kappa \leq \frac{n+1}{2}$. Let G be a graph of order n with $\kappa(G) = \kappa$. Then

$$\rho(G) - \pi(G) \leq \frac{n + 2\kappa - 3}{4\kappa} - \frac{(3\kappa + 1)(\kappa - 1)}{4\kappa(n - 1)}.$$

Proof. Let u and v be vertices of G such that $\bar{\sigma}(u) = \rho(G)$ and $\bar{\sigma}(v) = \pi(G)$, and let $k := d(u, v)$. For $i \in \mathbb{N} \cup \{0\}$ let $N_i(u)$ denote the set of vertices at distance i from u . Our first objective is to find a set $X \subseteq V(G)$ such that $\sigma(u|X) - \sigma(v|X)$ is small. We then bound $\sigma(u|V(G) - X) - \sigma(v|V(G) - X)$.

Since G is κ -connected, we have $|N_i(u)| \geq \kappa$ for all $i \in \{1, 2, \dots, \text{ecc}(u) - 1\}$. For $i \in \{1, 2, \dots, k - 1\}$, define M_i to be a set of exactly κ vertices of $N_i(u)$, and let $M_0 = \{u\}$ and $M_k = \{v\}$.

Clearly, $M_i \cap M_j = \emptyset$ for all $i, j \in \{0, 1, \dots, k\}$ with $i \neq j$. For $i \in \{0, 1, \dots, \lfloor \frac{k}{2} \rfloor\}$ define the sets $B_i = M_i \cup M_{k-i}$. Let $B = \bigcup_{i=0}^{\lfloor \frac{k}{2} \rfloor} B_i$, so $|B| = \kappa(k - 1) + 2$.

Note that for each $y \in M_i$, we have $d(u, y) = i$ and $k - i \leq d(v, y)$, and for each $y \in M_{k-i}$, we have $d(u, y) = k - i$ and $i \leq d(v, y)$. Hence, for $i \neq 0, k$,

$$\begin{aligned} \sigma(u|B_i) - \sigma(v|B_i) &= \sigma(u|M_i) + \sigma(u|M_{k-i}) - \sigma(v|M_i) - \sigma(v|M_{k-i}) \\ &\leq \kappa i + \kappa(k - i) - \kappa(k - i) - \kappa i \\ &= 0. \end{aligned}$$

By summing the above equation for $i \in \{1, \dots, \lfloor \frac{k}{2} \rfloor\}$, and noting that $\sigma(u|B_0) = d(u, v) = \sigma(v|B_0)$, we obtain that

$$\sigma(u|B) - \sigma(v|B) \leq 0. \tag{5.1}$$

Let $B' = V(G) - B$. Now consider $w \in B'$. We claim that

$$d(u, w) - d(v, w) \leq \begin{cases} k - 1 & \text{if } w \in B' \cap N_{\leq k}(u), \\ k & \text{if } w \in B' \cap N_{\geq k+1}(u). \end{cases} \tag{5.2}$$

Indeed, if $w \in B' \cap N_{\leq k}(u)$, then $d(u, w) \leq k$ and $d(v, w) \geq 1$, so $d(u, w) - d(v, w) \leq k - 1$. If $w \in B' \cap N_{\geq k+1}(u)$, then by the triangle inequality, we have

$$d(u, w) \leq d(u, v) + d(v, w),$$

and (5.2) follows since $d(u, v) = k$.

We first show that the theorem holds if $n \leq k\kappa$, that is, if there are only few vertices besides those in B . In this case we have $\text{diam}(G) \leq 1 + \frac{n-2}{\kappa} \leq 1 + \frac{k\kappa-2}{\kappa} < 1 + k$, and so all vertices of B' are in $B' \cap N_{\leq k}(u)$. Hence by (5.1) and (5.2) we obtain

$$\sigma(u) - \sigma(v) = \sigma(u|B) - \sigma(v|B) + \sum_{w \in B'} (d(u, w) - d(v, w)) \leq |B'|(k - 1).$$

Now $|B'| = n - ((k - 1)\kappa + 2) \leq \kappa - 2$ and $n \geq (k - 1)\kappa + 2$, which implies that $k - 1 \leq \frac{n-2}{\kappa}$. Substituting these bounds into the above inequalities and dividing by $n - 1$ implies that

$$\rho(G) - \pi(G) \leq \frac{\kappa - 2}{\kappa} \frac{n - 2}{n - 1},$$

which by a simple calculation, yields the theorem. Hence we may assume from now on that $n \geq k\kappa$.

Since $n > k\kappa$, we have $|B'| \geq \kappa - 1$. We claim that the set B' has at least $\kappa - 1$ vertices in $N_{\leq k}(u)$. Indeed, if less than $\kappa - 1$ vertices of B' are in $N_{\leq k}(u)$, then $N_{\geq k+1}$ is nonempty, and the set $N_k(u)$ is a cut-set containing not more than $\kappa - 2$ vertex besides v , a contradiction to G being κ -connected. Summing (5.2) over all $w \in B'$, we thus get

$$\begin{aligned} \sigma(u|B') - \sigma(v|B') &\leq \sum_{w \in B' \cap N_{\leq k}} (k - 1) + \sum_{w \in B' \cap N_{\geq k+1}} k \\ &\leq k(n - |B|) - (\kappa - 1) \\ &= k(n - (k - 1)\kappa - 2) - \kappa + 1. \end{aligned} \tag{5.3}$$

Combining equations (5.1) and (5.3), we obtain that

$$\begin{aligned} \sigma(u) - \sigma(v) &= \sigma(u|B) - \sigma(v|B) + \sigma(u|B') - \sigma(v|B') \\ &\leq k(n - (k - 1)\kappa - 2) - \kappa + 1. \end{aligned} \tag{5.4}$$

A straightforward maximisation shows that for $k = \frac{n+\kappa-2}{2\kappa}$, the right-hand side of the above inequality is maximised. Substituting this value of k into inequality (5.4), we obtain

$$\sigma(u) - \sigma(v) \leq \left(\frac{n + \kappa - 2}{2\kappa}\right)^2 - \kappa + 1.$$

Dividing by $n - 1$ in the above inequality yields, after simplification,

$$\rho(G) - \pi(G) \leq \frac{n + 2\kappa - 3}{4\kappa} - \frac{(\kappa - 1)(3\kappa + 1)}{4\kappa(n - 1)}.$$

This completes the proof of the theorem. □

The following example shows that for every κ the bound in Theorem 10 is sharp whenever $n \equiv \kappa + 2 \pmod{2\kappa}$.

Example 4. Fix $\kappa \in \mathbb{N}$ and let $n \in \mathbb{N}$ with $n \equiv \kappa + 2 \pmod{2\kappa}$. Let $\ell = \frac{n-2}{\kappa}$. Consider the graph $G_{n,\kappa}$, defined by

$$G_{n,\kappa} = K_1 + [K_\kappa]^\ell + K_1.$$

Clearly, $G_{n,\kappa}$ is a κ -connected graph of order $n = \ell\kappa + 2$. Let u be the vertex in the leftmost K_1 , and let v be a vertex in the $\frac{\ell+1}{2}$ th copy of K_κ . It is easy to verify that $\pi(G_{n,\kappa}) = \bar{\sigma}(v) = \frac{n+1}{4\kappa} + \frac{3(\kappa^2-1)}{4\kappa(n-1)}$. $\rho(G_{n,\kappa}) = \bar{\sigma}(u) = \frac{n+\kappa-1}{2\kappa} + \frac{\kappa-1}{2\kappa(n-1)}$. Hence $\rho(G_{n,\kappa}) - \pi(G_{n,\kappa}) = \frac{n+2\kappa-3}{4\kappa} - \frac{(3\kappa+1)(\kappa-1)}{4\kappa(n-1)}$, so the bound in Theorem 10 holds with equality.

For later use we note that $\text{diam}(G_{n,\kappa}) = \frac{n+\kappa-2}{\kappa}$.

For bipartite graphs, the bound in Theorem 10 can be improved slightly. This improved bound will yield a sharp bound for quadrangulations.

Theorem 11. *Let $n, \kappa \in \mathbb{N}$ with $\kappa \leq \frac{n+1}{2}$. Let G be a bipartite graph of order n with $\kappa(G) = \kappa$. Then*

$$\rho(G) - \pi(G) \leq \frac{n + 2\kappa - 3}{4\kappa} - \frac{(\kappa - 1)(7\kappa + 1)}{4\kappa(n - 1)}.$$

Proof. The proof is almost identical to that of Theorem 10, with the only difference being that we need the following slightly stronger version of (5.2):

$$d(u, w) - d(v, w) \leq \begin{cases} k - 2 & \text{if } w \in B' \cap N_{\leq k}(u), \\ k & \text{if } w \in B' \cap N_{\geq k+1}(u). \end{cases} \tag{5.5}$$

Indeed, if $w \in B' \cap N_k(u) - \{w\}$, then $d(u, w) = k$ and $d(v, w) \geq 2$, and if $w \in B' \cap N_{\leq k-1}(u) - \{w\}$, then $d(u, w) \leq k - 1$ and $d(v, w) \geq 1$, so $d(u, w) - d(v, w) \leq k - 2$ in either case. If $w \in B' \cap N_{\geq k+1}(v)$, then $d(u, w) - d(v, w) \leq k$ by the triangle inequality as in the proof of (5.2).

The remainder of the proof is identical to that of Theorem 10, and thus omitted. \square

The sharpness of Theorem 11 is shown by the following example.

Example 5. Fix $\kappa \in \mathbb{N}$ and let $n \in \mathbb{N}$ with $n \equiv \kappa + 2 \pmod{2\kappa}$. Let $\ell = \frac{n-2}{\kappa}$. Consider the graph $\overline{G}_{n,\kappa}$, defined by

$$\overline{G}_{n,\kappa} = K_1 + [\overline{K_\kappa}]^\ell + K_1.$$

Clearly, $\overline{G}_{n,\kappa}$ is a bipartite, κ -connected graph of order $n = \ell\kappa + 2$. Let u be the vertex in the leftmost K_1 , and let v be a vertex in the $\frac{\ell+1}{2}$ th copy of $\overline{K_\kappa}$. It is easy to verify that $\pi(\overline{G}_{n,\kappa}) = \overline{\sigma}(v) = \frac{n+1}{4\kappa} + \frac{7\kappa^2 - 4\kappa - 3}{4\kappa(n-1)}$. $\rho(\overline{G}_{n,\kappa}) = \overline{\sigma}(u) = \frac{n+\kappa-1}{2\kappa} + \frac{\kappa-1}{2\kappa(n-1)}$. Hence $\rho(\overline{G}_{n,\kappa}) - \pi(\overline{G}_{n,\kappa}) = \frac{n+2\kappa-3}{4\kappa} - \frac{(\kappa-1)(7\kappa+1)}{4\kappa(n-1)}$, so the bound in Theorem 11 holds with equality. For later use we note that $\text{diam}(\overline{G}_{n,\kappa}) = \frac{n+\kappa-2}{\kappa}$.

As corollaries to Theorems 10 and 11 we obtain sharp bounds on the difference between remoteness and proximity for the classes of planar graphs considered in Section 4.

Corollary 1. (a) *If G is a triangulation of order n , then*

$$\rho(G) - \pi(G) \leq \frac{n + 3}{12} - \frac{5}{3(n - 1)}.$$

(b) *If G is a 4-connected triangulation of order n , then*

$$\rho(G) - \pi(G) \leq \frac{n + 5}{16} - \frac{55}{16(n - 1)}.$$

(c) If G is a 5-connected triangulation of order n , then

$$\rho(G) - \pi(G) \leq \frac{n+7}{20} - \frac{26}{5(n-1)}.$$

(d) If G is a maximal outerplanar graph of order n , then

$$\rho(G) - \pi(G) \leq \frac{n+1}{8} + \frac{1}{8(n-1)}.$$

The bounds in (a)-(d) are sharp for infinitely many values of n .

Proof. Since every triangulation is 3-connected, and since every maximal outerplanar graph is 2-connected, we obtain the bounds in (a) and (d) from Theorem 10 for $\kappa = 3$ and $\kappa = 2$, respectively.

The triangulations in Example 1 attain the bound in (a), so the bound is sharp whenever $n \equiv 5 \pmod{6}$. The maximal outerplanar graphs in Example 3 attain the bound in (d), so the bound is sharp whenever $n \equiv 0 \pmod{4}$.

Similar examples show that also the bounds in (b) and (c) are sharp if $n \equiv 6 \pmod{8}$ and $n \equiv 7 \pmod{10}$, respectively. \square

Now we consider quadrangulations. Since every quadrangulation is bipartite and 2-connected, we obtain the following corollary to Theorem 11. The quadrangulations in Example 3 show that the bound in (a) is sharp for $n \equiv 0 \pmod{4}$. In a similar way one can construct 3-connected triangulations that show that the bound in (b) is sharp whenever $n \equiv 5 \pmod{6}$.

Corollary 2. (a) If G is a quadrangulation of order n , then

$$\rho(G) - \pi(G) \leq \frac{n+1}{8} - \frac{15}{8(n-1)}.$$

(b) If G is a 3-connected quadrangulation of order n , then

$$\rho(G) - \pi(G) \leq \frac{n+3}{12} - \frac{11}{3(n-1)}.$$

The graph in Example 2 shows that the bound in Corollary 2(a) is sharp whenever $n \equiv \kappa+2 \pmod{2\kappa}$. It is not hard to construct a similar 3-connected quadrangulation that shows that also Corollary 2(b) is sharp whenever $n \equiv \kappa+2 \pmod{2\kappa}$.

6. Diameter vs Proximity

In this section we compare diameter and proximity of graphs of given order and connectivity, and we show that the bound in Theorem 4 can be strengthened for κ -connected graphs by a factor of about $\frac{1}{\kappa}$. We first prove a sharp lower bound on the proximity in terms of order and connectivity, which we use to obtain an upper bound on the difference between diameter and proximity.

As corollaries we obtain bounds on the difference between diameter and proximity for triangulations, quadrangulations, and maximal outerplanar graphs. We construct graphs to show that these bounds are sharp apart from an additive constant.

In the proof of the main result of this section we make use of the following well-known bound on the diameter due to Watkins [31].

Proposition 2. [31] *If G is a κ -connected graph of order n , then*

$$\text{diam}(G) \leq \left\lfloor \frac{n + \kappa - 2}{\kappa} \right\rfloor.$$

Theorem 12. (a) *Let G be a κ -connected graph of order n and diameter d . Then*

$$\pi(G) \geq \begin{cases} \frac{\kappa(d-3)^2}{4(n-1)} + 1 + \frac{4(d-2)-\kappa}{4(n-1)} & \text{if } d \text{ is even,} \\ \frac{\kappa(d-3)^2}{4(n-1)} + 1 + \frac{d-2}{n-1} & \text{if } d \text{ is odd,} \end{cases}$$

(b) *Let G be a κ -connected graph of order n . Then*

$$\text{diam}(G) - \pi(G) \leq \frac{3n - 9}{4\kappa} + 1 - \frac{3\kappa^2 - 3}{4\kappa(n - 1)}.$$

Proof. Let G be a κ -connected graph of order n . Define $d = \text{diam}(G)$, and let v, w_0, w_d be vertices of G , where $\bar{\sigma}(v) = \pi(G)$ and $d(w_0, w_d) = \text{diam}(G)$. Since G is κ -connected, each $N_i(w_0)$, $i \in \{1, 2, \dots, d - 1\}$, contains at least κ vertices. For each $i = 1, 2, \dots, d - 1$ define M_i to be a set of κ vertices of $N_i(w_0)$. Clearly, $M_i \cap M_j = \emptyset$ for all $i, j \in \{1, 2, \dots, d - 1\}$ with $i \neq j$. Define $B_0 = \{w_0, w_d\}$ and $B_i = M_i \cup M_{d-i}$ for $i = 1, \dots, \lfloor \frac{d}{2} \rfloor - 1$, and let $B = \bigcup_{i=0}^{\lfloor \frac{d}{2} \rfloor - 1} B_i$. Then $|B| = 2 + \kappa(d - 2)$ if d is even, and $|B| = 2 + \kappa(d - 3)$ if d is odd.

To bound $\sigma(v|B)$ from below, consider $\sigma(v|M_i \cup M_{d-i})$ for $i = 1, \dots, \lfloor \frac{d}{2} \rfloor - 1$. Using the triangle inequality, we obtain $d(v, a) + d(v, b) \geq d(a, b) \geq d - 2i$ for any $a \in M_i$ and $b \in M_{d-i}$. This yields the following bound.

$$\sigma(v|B_i) = \sigma(v|M_i) + \sigma(v|M_{d-i}) \geq \kappa(d - 2i).$$

Summing over all $i \in \{1, \dots, \lfloor \frac{d}{2} \rfloor - 1\}$, and taking into account that $d(v, w_0) + d(v, w_d) \geq d(w_0, w_d) = d$, we obtain:

$$\sigma(v|B) = \sum_{i=0}^{\lfloor \frac{d}{2} \rfloor - 1} \sigma(v|B_i) \geq d + \sum_{i=1}^{\lfloor \frac{d}{2} \rfloor - 1} \kappa(d - 2i).$$

Hence,

$$\sigma(v|B) \geq \begin{cases} d + \frac{1}{4}\kappa(d^2 - 2d) & \text{if } d \text{ is even,} \\ d + \frac{1}{4}\kappa(d^2 - 2d - 3) & \text{if } d \text{ is odd.} \end{cases} \tag{6.1}$$

We now bound the transmission of v from below. Since there are $n - |B|$ vertices not in B , and of those at least $n - |B| - 1$ are distinct from v , we obtain by (6.1) that

$$\begin{aligned} \sigma(v, G) &\geq \sigma(v|B) + (n - |B| - 1) \\ &\geq \begin{cases} d + \frac{1}{4}\kappa(d^2 - 2d) + n - \kappa(d - 2) - 3 & \text{if } d \text{ is even,} \\ d + \frac{1}{4}\kappa(d^2 - 2d - 3) + n - \kappa(d - 3) - 3 & \text{if } d \text{ is odd.} \end{cases} \end{aligned} \tag{6.2}$$

Dividing by $n - 1$ in (6.2) yields, after simplification,

$$\pi(G) \geq \begin{cases} \frac{\kappa(d-3)^2}{4(n-1)} + 1 + \frac{d-2}{n-1} - \frac{\kappa}{4(n-1)} & \text{if } d \text{ is even,} \\ \frac{\kappa(d-3)^2}{4(n-1)} + 1 + \frac{d-2}{n-1} & \text{if } d \text{ is odd,} \end{cases}$$

which is the desired lower bound on $\pi(G)$. This proves (a).

(b) We now bound the difference between the diameter and proximity. Recall that $d = \text{diam}(G)$. From (a) we have that $\pi(G) \geq \frac{\kappa(d-3)^2}{4(n-1)} + 1 + \frac{d-2}{n-1} - \frac{\kappa}{4(n-1)}$. Hence

$$\text{diam}(G) - \pi(G) \leq d - \frac{\kappa(d-3)^2}{4(n-1)} - 1 - \frac{d-2}{n-1} + \frac{\kappa}{4(n-1)}. \tag{6.3}$$

Denote the right-hand side of (6.3) by $f(d)$. Then $f'(d) = 1 - \frac{1}{2(n-1)}[\kappa(d-3) + 2]$. Since $d \leq \frac{n+\kappa-2}{\kappa}$ by Proposition 2, it follows that $f'(d) > 0$, so f is increasing and $f(d)$ attains its maximum for $1 \leq d \leq \frac{n+\kappa-2}{\kappa}$ at $d = \frac{n+\kappa-2}{\kappa}$. Substituting this value into (6.3) yields, after simplification,

$$\text{diam}(G) - \pi(G) \leq f\left(\frac{n+\kappa-2}{\kappa}\right) = \frac{3n-9}{4\kappa} + 1 - \frac{3\kappa^2-3}{4\kappa(n-1)},$$

as desired. □

We note that the case $\kappa = 1$ yields a lower bound on the proximity of a tree of given order n and diameter d given in [28] if n is odd. It also yields the bound on the difference $\text{diam}(G) - \pi(G)$ in Theorem 4 for the case that n is odd. For even n , our bound for $\kappa = 1$ differs from that in Theorem 4 by a term $o(n)$.

The bound in Theorem 12(a) is sharp for every n, d, κ with $d \leq \frac{n-2}{\kappa} + 1$.

Example 6. Let $n, d, \kappa \in \mathbb{N}$ with $d \leq \frac{n-2}{\kappa} + 1$. First let d be even. Define $\ell = \frac{d}{2}$, and let

$$G = K_1 + [K_\kappa]^{\ell-1} + K_{n-\kappa(d-2)-2} + [K_\kappa]^{\ell-1} + K_1.$$

Clearly, G is a κ -connected graph of order n and diameter d , and the median vertices of G are exactly the vertices in $K_{n-\kappa(d-2)-2}$. Let v be a median vertex. A straightforward calculation shows that

$$\sigma(v) = (n - \kappa(d - 2) - 3) + \sum_{i=1}^{\ell-1} 2\kappa i + 2\ell.$$

Dividing by $n - 1$ and simplifying yields

$$\pi(G) = \bar{\sigma}(v) = \frac{\kappa(d - 3)^2}{4(n - 1)} + 1 + \frac{4(d - 2) - \kappa}{4(n - 1)},$$

which is the bound in Theorem 12(a) for even d .

Now let d be odd. Define $\ell = \frac{d-1}{2}$, and let

$$G = K_1 + [K_\kappa]^\ell + K_{n-\kappa(d-2)-2} + [K_\kappa]^{\ell-1} + K_1.$$

It is easy to see that the vertices in $K_{n-\kappa(d-2)-2}$ are median vertices of G . Calculations similar to the case that d is even show that their average distance, i.e., $\pi(G)$, attains the bound in Theorem 12(a).

Example 4 shows that if, in addition, $n \equiv \kappa + 2 \pmod{2\kappa}$, then the bound in Theorem 12(b) is also sharp.

Corollary 3. *Let G be a planar graph of order $n \geq 4$.*

(a) *If G is a triangulation, then*

$$\text{diam}(G) - \pi(G) \leq \frac{n + 1}{4} - \frac{2}{n - 1}.$$

(b) *If G is a 4-connected triangulation, then*

$$\text{diam}(G) - \pi(G) \leq \frac{3n + 7}{16} - \frac{45}{16(n - 1)}.$$

(c) *If G is a 5-connected triangulation, then*

$$\text{diam}(G) - \pi(G) \leq \frac{3n + 11}{20} - \frac{18}{5(n - 1)}.$$

(d) *If G is a quadrangulation, then*

$$\text{diam}(G) - \pi(G) \leq \frac{3n - 1}{8} - \frac{9}{8(n - 1)}.$$

(e) If G is a 3-connected quadrangulation, then

$$\text{diam}(G) - \pi(G) \leq \frac{n+1}{4} - \frac{2}{n-1}.$$

(f) If G is a maximal outerplanar graph, then

$$\text{diam}(G) - \pi(G) \leq \frac{3n-1}{8} + \frac{9}{8(n-1)}.$$

The graphs defined in Example 1 show that the bound in Corollary 3 is sharp. In a similar way, it is easy to construct 4-connected and 5-connected planar graphs that demonstrate the sharpness of the bounds in (b) and (c).

The graphs in Example 2 show that the bound in (d) is sharp part from an additive constant. In a similar way, it is easy to construct 3-connected quadrangulations that demonstrate the sharpness, up to an additive constant, of the bound in (e).

Finally, the graphs in Example 3 show that the bound in (f) is sharp.

Conflict of Interest: P. Dankelmann is an editor of Communications in Combinatorics and Optimization. The authors have no other financial or non-financial conflicts of interest.

Data Availability: Data sharing is not applicable to this article as no datasets were generated or analyzed during the current study.

References

- [1] J. Ai, S. Gerke, G. Gutin, and S. Mafunda, *Proximity and remoteness in directed and undirected graphs*, Discrete Math. **344** (2021), no. 3, 112252.
<https://doi.org/10.1016/j.disc.2020.112252>.
- [2] P. Ali, P. Dankelmann, and S. Mukwembi, *The radius of k -connected planar graphs with bounded faces*, Discrete Appl. Math. **312** (2012), no. 24, 3636–3642.
<https://doi.org/10.1016/j.disc.2012.08.019>.
- [3] M. Aouchiche, G. Caporossi, and P. Hansen, *Variable neighbourhood search for extremal graphs. 20. Automated comparison of graph invariants*, MATCH Commun. Math. Comput. Chem. **58** (2007), no. 2, 365–384.
- [4] M. Aouchiche and P. Hansen, *Proximity and remoteness in graphs: Results and conjectures*, Networks **58** (2011), no. 2, 95–102.
<https://doi.org/10.1002/net.20450>.
- [5] ———, *Proximity, remoteness and girth in graphs*, Discrete Appl. Math. **222** (2017), 31–39.
<https://doi.org/10.1016/j.dam.2017.01.025>.
- [6] M. Aouchiche and B.A. Rather, *Proximity and remoteness in graphs: A survey*, Discrete Appl. Math. **353** (2024), 94–120.
<https://doi.org/10.1016/j.dam.2024.04.012>.

- [7] Z. Che and K.L. Collins, *An upper bound on Wiener indices of maximal planar graphs*, Discrete Appl. Math. **258** (2019), 76–86.
<https://doi.org/10.1016/j.dam.2018.11.026>.
- [8] M. Cheng, H. Lin, and B. Zhou, *Minimum status of series-reduced trees with given parameters*, Bull. Braz. Math. Soc., New Series **53** (2022), 701–720.
<https://doi.org/10.1007/s00574-021-00278-1>.
- [9] É. Czabarka, P. Dankelmann, T. Olsen, and L.A. Székely, *Wiener index and remoteness in triangulations and quadrangulations*, Discrete Math. Theor. Comp. Sci. **23** (2021), no. 1, #3.
<https://doi.org/10.46298/dmtcs.6473>.
- [10] ———, *Proximity in triangulations and quadrangulations*, Electron. J. Graph Theory Appl. **10** (2022), no. 2, 425–446.
<https://doi.org/10.5614/ejgta.2022.10.2.7>.
- [11] P. Dankelmann, *Proximity, remoteness, and minimum degree*, Discrete Appl. Math. **184** (2015), 223–228.
<https://doi.org/10.1016/j.dam.2014.11.012>.
- [12] ———, *New bounds on proximity and remoteness in graphs*, Commun. Comb. Optim. **1** (2016), no. 1, 29–41.
<https://doi.org/10.22049/cco.2016.13543>.
- [13] P. Dankelmann, E. Jonck, and S. Mafunda, *Proximity and remoteness in triangle-free and C_4 -free graphs in terms of order and minimum degree*, Discrete Math. **344** (2021), no. 9, 112513.
<https://doi.org/10.1016/j.disc.2021.112513>.
- [14] P. Dankelmann and S. Mafunda, *On the difference between proximity and other distance parameters in triangle-free graphs and C_4 -free graphs*, Discrete Appl. Math. **321** (2022), 295–307.
<https://doi.org/10.1016/j.dam.2022.06.037>.
- [15] P. Dankelmann, S. Mafunda, and S. Mallu, *Proximity, remoteness and maximum degree in graphs*, Discrete Math. Theoretical Comp. Science **24** (2022), no. 2, #10.
<https://doi.org/10.46298/dmtcs.9432>.
- [16] ———, *Proximity and radius in outerplanar graphs with bounded faces*, Discrete Math. **349** (2026), no. 11, 115250.
<https://doi.org/10.1016/j.disc.2026.115250>.
- [17] A.J. Goldman, *Minimax location of a facility in a network*, Trans. Sci. **6** (1972), no. 4, 407–418.
<https://doi.org/10.1287/trsc.6.4.407>.
- [18] S.L. Hakimi, *Optimum locations of switching centers and the absolute centers and medians of a graph*, Oper. Res. **12** (1964), no. 3, 450–459.
- [19] H. Hua, Y. Chen, and K.C. Das, *The difference between remoteness and radius of a graph*, Discrete Appl. Math. **187** (2015), 103–110.
<https://doi.org/10.1016/j.dam.2015.02.007>.
- [20] H. Hua and K.C. Das, *Proof of conjectures on remoteness and proximity in graphs*, Discrete Appl. Math. **171** (2014), 72–80.

- <https://doi.org/10.1016/j.dam.2014.02.011>.
- [21] J. Leydold and P.F. Stadler, *Minimal cycle bases of outerplanar graphs*, The Electronic Journal of Combinatorics **5** (1998), no. 1, #R16.
<https://doi.org/10.37236/1354>.
- [22] C. Liang, B. Zhou, and H. Guo, *Minimum status, matching and domination of graphs*, The Computer Journal **64** (2021), no. 9, 1384–1392.
- [23] C. Lin, W.H. Tsai, J.L. Shang, and Y.J. Zhang, *Minimum statuses of connected graphs with fixed order and maximum degree*, J. Comb. Optim. **24** (2012), 147–161.
<https://doi.org/10.1007/s10878-011-9412-4>.
- [24] H. Lin, K.C. Das, and B. Wu, *Remoteness and distance eigenvalues of a graph*, Discrete Appl. Math. **215** (2016), 218–224.
<https://doi.org/10.1016/j.dam.2016.07.018>.
- [25] B. Ma, B. Wu, and W. Zhang, *Proximity and average eccentricity of a graph*, Inform. Process. Lett. **112** (2012), no. 10, 392–395.
<https://doi.org/10.1016/j.ipl.2012.02.001>.
- [26] S. Mallu, *Bounds on proximity and remoteness in graphs and digraphs*, Ph.D. thesis, University of Johannesburg, Johannesburg, Gauteng, South Africa, 2026.
- [27] L. Pei, X. Pan, K. Wang, and J. Tian, *Proofs of the AutoGraphiX conjectures on the domination number, average eccentricity and proximity*, Discrete Appl. Math. **289** (2021), 292–301.
<https://doi.org/10.1016/j.dam.2020.11.012>.
- [28] Z. Peng and B. Zhou, *Minimum status of trees with given parameters*, RAIRO-Oper. Res. **55** (2021), S765–S785.
<https://doi.org/10.1051/ro/2020015>.
- [29] R. Rissner and R.E. Burkard, *Bounds on the radius and status of graphs*, Networks **64** (2014), no. 2, 76–83.
<https://doi.org/10.1002/net.21558>.
- [30] J. Sedlar, *Remoteness, proximity and few other distance invariants in graphs*, Filomat **27** (2013), no. 8, 1425–1435.
<https://doi.org/10.2298/FIL1308425S>.
- [31] M.E. Watkins, *A lower bound for the number of vertices of a graph*, The American Mathematical Monthly **74** (1967), no. 3, 297–297.
- [32] H. Whitney, *2-Isomorphic graphs*, Amer. J. Math. **55** (1933), no. 1, 245–254.
- [33] B. Wu and W. Zhang, *Average distance, radius and remoteness of a graph*, Ars Math. Contemp. **7** (2014), no. 2, 441–452.
- [34] B. Zelinka, *Medians and peripherians of trees*, Arch. Math. (Brno) **4** (1968), no. 2, 87–95.