

On the metric dimension and spectrum of graphs

Mohammad Farhan¹, Edy Tri Baskoro^{2,3,*}

¹Master Program of Mathematics, Faculty of Mathematics and Natural Sciences,
Institut Teknologi Bandung, Bandung, Indonesia
20122015@mahasiswa.itb.ac.id

²Combinatorial Mathematics Research Group, Faculty of Mathematics and Natural Sciences,
Institut Teknologi Bandung, Bandung, Indonesia

³Center for Research Collaboration on Graph Theory and Combinatorics, Indonesia
*ebaskoro@itb.ac.id

Received: 29 October 2023; Accepted: 14 August 2024

Published Online: 7 September 2024

Abstract: The algebraic approach to graph theoretical problems has been extensively studied by looking at the spectrum of a graph's representation matrix. In this paper, we investigate some relationships between the metric dimension of a graph G and its nullity, that is, the multiplicity of eigenvalue 0 in the adjacency matrix of G , and the eigenvalues of its Laplacian and distance matrices. Furthermore, we also present a relationship between the metric dimension of a graph and its nullity, using twin classes.

Keywords: metric dimension, spectrum, nullity, twin classes.

AMS Subject classification: 05C05, 05C12, 05C50

1. Introduction

Throughout this paper, all graphs are finite, simple, and undirected. The concept of metric dimension of a graph was introduced by Slater [26] and by Harary and Melter [16] independently as a distance-based concept on graphs. They introduced the term *locating set* or *resolving set* as a set of vertices which is used as a reference to identify each vertex of a graph uniquely. Research on graph metric dimension and its variations has grown rapidly in the last decades as they have direct applications to some real world problems such as robot navigation [20] and chemistry [6]. See the works of Tillquist, Frongillo, and Lladser [27], and Kuziak and Yero [21] for surveys on

* *Corresponding Author*

the metric dimension of graphs, and [1, 7, 25] for some recent research on this topic. Furthermore, it is known that the problem of determining the metric dimension of a graph is NP-complete [13].

The algebraic approach to graph theoretical problems has been extensively studied, specifically by using matrices to represent a graph. Matrix properties such as eigenvalues, rank, determinant, etc., may give information on the structure of the graph it represents. See, for example, the works of Bapat [3], Biggs [5], and Cvetković, Rowlinson, and Simić [8], and the references cited therein for extensive results on this topic. In this paper, we investigate some relations between the metric dimension of a graph with the eigenvalues of its adjacency, distance, and Laplacian matrix.

In general, we refer to Diestel [10] for the basic definitions related to graphs. An *empty graph* \emptyset is the graph without any vertices and edges. Let $G = (V, E)$ be a graph. Two vertices $u, v \in V$ are said to be *adjacent* if $uv \in E$. The *open neighborhood* of a vertex $u \in V$ is the set $N_G(u) := \{v \in V : uv \in E\}$, and the *closed neighborhood* of u is $N_G[u] := \{u\} \cup N_G(u)$. The *degree* of a vertex $u \in V$, denoted by $\deg(u)$, is the size of $N_G(u)$. A vertex is called *pendant* if it has degree one and *quasipendant* if it is adjacent to a pendant vertex. Let $p(G)$ and $q(G)$ denote the number of pendant and quasipendant vertices of G , respectively. For two distinct vertices u, v in a graph G , the *distance* $d(u, v)$ of u and v is the length of a shortest path connecting u and v . For two integers $a \leq b$, we define $[a, b] := \{x \in \mathbb{Z} : a \leq x \leq b\}$.

Let $G = (V, E)$ be a graph and $u, v \in V$, $u \neq v$. We say that a vertex $s \in V$ *resolves* u and v if $d(u, s) \neq d(v, s)$. Let $S = \{s_1, s_2, \dots, s_k\} \subseteq V$ be an ordered subset of V . The *representation* of $v \in V$ with respect to S , denoted by $r(v|S)$, is defined as $r(v|S) = (d(v, s_1), d(v, s_2), d(v, s_3), \dots, d(v, s_k))$. We call S a *resolving set* of G if each vertex of G has a unique representation with respect to S , that is, $r(u|S) \neq r(v|S)$ for every distinct pair $u, v \in V$. In other words, S is a resolving set if and only if every pair of distinct vertices $u, v \in V$ is resolved by an element of S . A resolving set of G with minimum size is called a *basis* of G . The cardinality of a basis of G is called the *metric dimension* of G , denoted by $\dim(G)$.

Example 1. Consider the graph G in Figure 1 where $V(G) = \{v_1, v_2, v_3, v_4, v_5\}$. Let $S = \{v_3, v_5\} \subseteq V(G)$ where the nodes v_3 and v_5 are circled. The representations of all vertices in G with respect to S are given, namely, $r(v_1|S) = (1, 2)$, $r(v_2|S) = (1, 1)$, $r(v_3|S) = (0, 1)$, $r(v_4|S) = (2, 1)$, and $r(v_5|S) = (1, 0)$. Since all vertices in G have distinct representations with respect to S , it follows that S is a resolving set of G of size 2. Furthermore, since the minimum vertex degree in G is 2, we have that for any singleton $T = \{v\}$, where $v \in V(G)$, there are at least two neighbors of v , say x and y , where $r(x|T) = (1) = r(y|T)$. Thus, any singleton in G cannot be a resolving set of G . Therefore, S is a basis of G , and $\dim(G) = 2$.

Let $G = (V, E)$ be a graph of order n with $V = \{v_1, v_2, \dots, v_n\}$. The *adjacency matrix* of G is the $n \times n$ matrix $\mathbf{A} = \mathbf{A}(G) = \mathbf{A}_G$ whose entry a_{ij} is equal to 1 if v_i and v_j are adjacent, and 0 otherwise. The *Laplacian matrix*, or simply Laplacian, of G is defined as $\mathbf{L} = \mathbf{L}(G) := \Delta - \mathbf{A}(G)$, where $\Delta = \text{diag}(\deg(v_1), \deg(v_2), \dots, \deg(v_n))$.

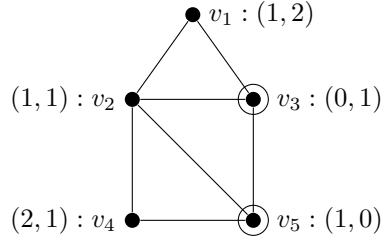

Figure 1. The graph G and the representations of all vertices in G with respect to S

The *distance matrix* of G is the matrix $\mathbf{D} = \mathbf{D}(G) = (d_{ij})$, where $d_{ij} = d(v_i, v_j)$. For $\mathbf{M} \in \{\mathbf{A}, \mathbf{L}, \mathbf{D}\}$, the \mathbf{M} -*spectrum* of G , denoted by $\text{spec}_{\mathbf{M}}(G)$, is the set of eigenvalues of $\mathbf{M}(G)$ together with their multiplicities. If the distinct eigenvalues of $\mathbf{M}(G)$ are $\lambda_1 > \lambda_2 > \dots > \lambda_s$, and their multiplicities are m_1, m_2, \dots, m_s , respectively, then we write $\text{spec}_{\mathbf{M}}(G) = \{\lambda_1^{m_1}, \lambda_2^{m_2}, \dots, \lambda_s^{m_s}\}$. For an eigenvalue λ , we may write $m_{\mathbf{M}}(\lambda)$ to denote the multiplicity of λ in $\text{spec}_{\mathbf{M}}(G)$. The *nullity* of G , denoted by $\eta(G)$, is the multiplicity of eigenvalue 0 in $\text{spec}_{\mathbf{A}}(G)$, that is, $\eta(G) = m_{\mathbf{A}}(0)$. For the trivial case, we define $\eta(\emptyset) = 0$. For further discussions on graph nullity, see a nice survey paper by Gutman and Borovicanin [15]. The followings are some fundamental results on the nullity of graphs which will be useful in our results.

Lemma 1 ([9]). *Let G be a bipartite graph containing a pendant vertex, say v , and H be the graph obtained from G by deleting v and its neighbor. Then, $\eta(G) = \eta(H)$.*

Lemma 2 ([15]). *Let $G = G_1 \cup G_2 \cup \dots \cup G_t$, where G_1, G_2, \dots, G_t are connected components of G . Then, $\eta(G) = \sum_{i=1}^t \eta(G_i)$.*

For the \mathbf{L} -spectrum and \mathbf{D} -spectrum of a tree, we have the following results.

Theorem 1 ([14]). *Let T be a tree of order $n \geq 2$. If μ is an eigenvalue of $\mathbf{L}(T)$, then $m_{\mathbf{L}}(\mu) \leq p(T) - 1$.*

Theorem 2 ([11]). *If T is a tree of order $n \geq 2$, then $m_{\mathbf{L}}(1) \geq p(T) - q(T)$.*

Corollary 1 ([23]). *Let T be a tree of order $n \geq 2$. If ϑ is an eigenvalue of $\mathbf{D}(T)$, then $m_{\mathbf{D}}(\vartheta) \leq p(T)$.*

Corollary 2 ([23]). *If T is a tree of order $n \geq 2$, then $m_{\mathbf{D}}(-2) \geq p(T) - q(T) - 1$.*

This paper is organized as follows. Section 2 is devoted to investigating some relations between the metric dimension of a tree and its nullity, \mathbf{L} -spectrum, and \mathbf{D} -spectrum. Section 3 discusses the relationship between the metric dimension of a graph and its

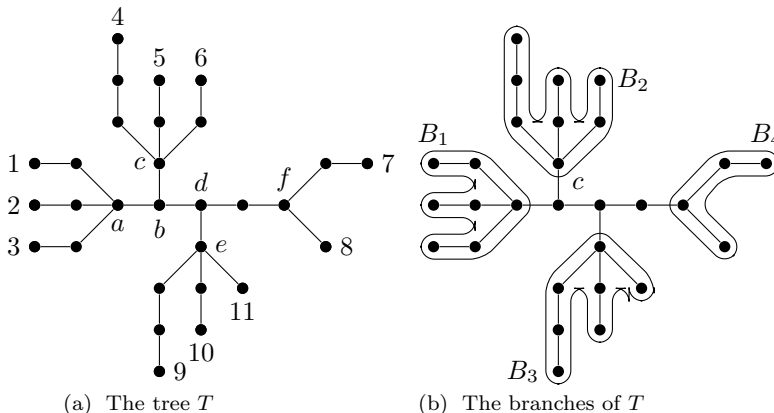

Figure 2. The tree T with its pendants, major vertices, and branches

nullity using twin classes. Later in Section 4, we provide some open problems related to our results.

2. The metric dimension and spectrum of trees

Before we state our main results, we present some elementary definitions, results, and observations that motivate this discussion. The following definitions can be found in [6]. A vertex of degree at least 3 in a graph G is called a *major vertex* of G . Any pendant vertex u of G is said to be a *terminal vertex of a major vertex* v of G if $d(u, v) < d(u, w)$ for every other major vertex w of G . The *terminal degree* $\text{ter}(v)$ of a major vertex v is the number of terminal vertices of v . A major vertex v of G is an *exterior major vertex* of G if it has a positive terminal degree. Let $\text{ex}(G)$ denote the number of exterior major vertices of G . In [6], Chartrand, Eroh, Johnson, and Oellermann described the metric dimension of a tree in the following way.

Theorem 3 ([6]). *If T is a tree other than a path, then $\dim(T) = p(T) - \text{ex}(T)$.*

Example 2. Let us observe the tree T in Figure 2. The pendant vertices of T are $[1, 11]$, hence $p(T) = 11$. The major vertices of T are $\{a, b, c, d, e, f\}$. For the major vertex a , its terminal vertices are $\{1, 2, 3\}$, hence $\text{ter}(a) = 3$. On the other hand, the major vertex b has no terminal vertex, hence $\text{ter}(b) = 0$. For the remaining major vertices, we have $\text{ter}(c) = 3$, $\text{ter}(d) = 0$, $\text{ter}(e) = 3$, and $\text{ter}(f) = 2$. It follows that the exterior major vertices of G are $\{a, c, e, f\}$, hence $\text{ex}(T) = 4$. Therefore, Theorem 3 implies $\dim(T) = p(T) - \text{ex}(T) = 11 - 4 = 7$.

In this paper, we use the following additional terms. For an exterior major vertex v in G , a *tail of v* is a path connecting v to one of its terminal vertex, excluding v .

Thus, an exterior major vertex v has $\text{ter}(v)$ tails. Note that the term *legs* used in [20] is equivalent to tails in this paper. We call a tail *odd* or *even* if it has an odd or even number of vertices, respectively. A *branch* B is a subgraph of G induced by an exterior major vertex v in G and all of its tails. In this case, we call v the *stem vertex* of B . Thus, a branch with n tails is a subdivision of the star graph $K_{1,n}$. We say a branch B is of Type I if it has at least one odd tail and Type II otherwise. In Figure 2, the branches of T in Figure 2 are the blocked subgraphs B_1, B_2, B_3 , and B_4 . The vertex c is the stem of B_2 . The branches B_2, B_3 , and B_4 are of Type I, while the branch B_1 is of Type II.

With these additional definitions, we may rewrite the metric dimension formula for a tree T as in the following theorem, an equivalent result that was proved in [20]. This indicates that the metric dimension of a tree depends only on the structure of its branches.

Theorem 4 ([20]). *If T be a tree other than a path, then*

$$\dim(T) = \sum_{v \in V; \text{ter}(v) > 1} (\text{ter}(v) - 1).$$

This discussion is motivated by the following observation. Consider a star graph $K_{1,n}$ where $n \geq 2$. By Theorem 3 or Theorem 4, it is easy to see that $\dim(K_{1,n}) = n - 1$. On the other hand, it is easy to verify that the nullity of $K_{1,n}$ is also $n - 1$, that is, $\eta(K_{1,n}) = n - 1$. Thus, we have $\dim(K_{1,n}) = \eta(K_{1,n})$. Since the metric dimension of a tree only depends on the structure of its branches (Theorem 4), and a branch is a subdivision of a star graph with the same number of tails, whose nullity is known, we suspect that there is a connection between the metric dimension of trees with their nullity. In fact, as we prove in our results, this is indeed the case.

Now, we are ready to state our main results on the metric dimension of a tree in terms of its nullity and some of its subgraphs. First, we consider the case where the tree has at least one odd tail.

Theorem 5. *Let T be a tree other than a path. Let \mathcal{B}_I and \mathcal{B}_{II} be the sets of Type I and Type II branches in T , respectively. Let e_2 be the number of even tails in T . If T has an odd tail, then*

$$\dim(T) = \eta(T) - \eta(T - \mathcal{B}_I) - |\mathcal{B}_{II}| + e_2$$

where $T - \mathcal{B}_I$ is the graph obtained from T by deleting all Type I branches in T .

Proof. Let B_1, \dots, B_k be the branches in T . Since T has at least one odd tail, there exists a Type I branch in T . Suppose that $|\mathcal{B}_I| = p \geq 1$. Without loss of generality, let $\mathcal{B}_I = \{B_1, B_2, \dots, B_p\}$ and $\mathcal{B}_{II} = \{B_{p+1}, B_{p+2}, \dots, B_k\}$. Observe that we may construct a sequence of graphs G_0, G_1, \dots, G_p where $G_0 := T$, $G_p = T - \mathcal{B}_I$, and $G_j = G_{j-1} - B_j = T - \bigcup_{i=1}^j B_i$ for $j \in [1, p]$. So, the graph G_j is obtained from T by deleting the branches B_1, B_2, \dots, B_j of T .

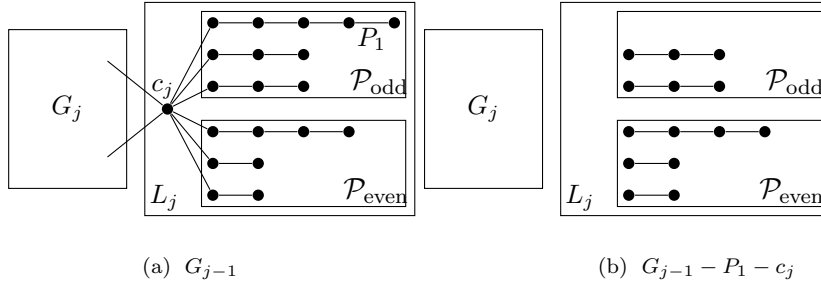

Figure 3. (a) The grouping of the vertices in G_{j-1} and (b) the connected components of $G_{j-1} - P_1 - c_j$

For an arbitrary $j \in [1, p]$, consider the graph G_{j-1} and Type I branch B_j with stem vertex c_j . Suppose that B_j has $e^{(j)}$ tails, $e_1^{(j)}$ odd tails, and $e_2^{(j)}$ even tails, hence $e^{(j)} = e_1^{(j)} + e_2^{(j)}$ and $e_2 = \sum_{i=1}^k e_2^{(i)}$. Let \mathcal{P}_{odd} be the set of all odd tails of B_j , and let $\mathcal{P}_{\text{even}}$ be the set of all even tails of B_j . Pick an arbitrary odd tail, say P_1 , and then delete P_1 and c_j from G_{j-1} . Since P_1 is an odd tail, we have $\eta(G_{j-1}) = \eta(G_{j-1} - P_1 - c_j)$ by Lemma 1. Observe that the graph $G_{j-1} - P_1 - c_j$ has several connected components (see Figure 3): G_j , odd tails of B_j except P_1 , and even tails of B_j . By Lemma 1, we have

$$\eta(P) = \begin{cases} 1, & \text{if } P \in \mathcal{P}_{\text{odd}}, \\ 0, & \text{if } P \in \mathcal{P}_{\text{even}}, \end{cases}$$

since successively deleting a pendant vertex and its neighbor of a path yields a single vertex if it has an odd order, and an empty graph if it has an even order. Consequently, by Lemma 2, we have

$$\begin{aligned} \eta(G_{j-1}) &= \eta(G_{j-1} - P_1 - c_j) \\ &= \eta(G_j) + \sum_{P \in \mathcal{P}_{\text{odd}}} \eta(P) + \sum_{P \in \mathcal{P}_{\text{even}}} \eta(P) \\ &= \eta(G_j) + (e_1^{(j)} - 1) \end{aligned}$$

Therefore, we have the relation $\eta(G_j) = \eta(G_{j-1}) - (e_1^{(j)} - 1)$ for $j \in [1, p]$. By applying this relation successively, we obtain

$$\eta(T - \mathcal{B}_1) = \eta(G_p) = \eta(G_0) - \sum_{i=1}^p (e_1^{(i)} - 1) = \eta(T) - \sum_{i=1}^p (e_1^{(i)} - 1).$$

Finally, since $\sum_{i=1}^k (e^{(i)} - 1) = \dim(T)$ by Theorem 4, we have

$$\begin{aligned} \eta(T - \mathcal{B}_I) &= \eta(T) - \sum_{i=1}^k (e_1^{(i)} - 1) + \sum_{i=p+1}^k (e_1^{(i)} - 1) \\ &= \eta(T) - \sum_{i=1}^k (e^{(i)} - 1 - e_2^{(i)}) + \sum_{i=p+1}^k (0 - 1) \\ &= \eta(T) - \sum_{i=1}^k (e^{(i)} - 1) + \sum_{i=1}^k e_2^{(i)} - (k - p) \\ &= \eta(T) - \dim(T) + e_2 - k + p. \end{aligned}$$

Since $k - p = |\mathcal{B}_{II}|$, the result follows. □

Example 3. Let us reobserve the tree T in Figure 2. The subgraph $T - \mathcal{B}_I$ is depicted in Figure 4. It is easy to verify using Lemma 1 that $\eta(T) = 1$, $\eta(T - \mathcal{B}_I) = 0$, $|\mathcal{B}_{II}| = 1$, and $e_2 = 7$. Therefore, by Theorem 5, we obtain $\dim(T) = \eta(T) - \eta(T - \mathcal{B}_I) - |\mathcal{B}_{II}| + e_2 = 1 - 0 - 1 + 7 = 7$, the same result as in Example 2.

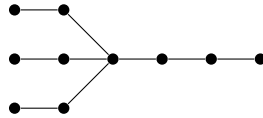

Figure 4. $T - \mathcal{B}_I$

The following theorem gives another relationship between the metric dimension of a tree other than a path and the nullity of some graph operations applied to the tree. In this theorem, we no longer need information about Type I and Type II branches of the tree, as in Theorem 5. For that, we need the following definitions. Let T be a tree. We denote by $s(T)$ the tree obtained from T by subdividing every edge of T once. We denote by $[T]_p$ ($[T]_b$) the tree obtained from T by deleting all of its pendant vertices (branches).

Theorem 6. *If T is a tree other than a path, then*

$$\dim(T) = \eta([s(T)]_p) - \eta([s(T)]_b).$$

Furthermore, if T has only even tails, then

$$\dim(T) = \eta([T]_p) - \eta([T]_b).$$

Proof. We prove the first part. Observe that $s(T)$ has only even tails, so all tails of $[s(T)]_p$ are odd and all branches of $[s(T)]_p$ are of Type I. By Theorem 5, we have

$$\dim([s(T)]_p) = \eta([s(T)]_p) - \eta([s(T)]_p - \mathcal{B}_I) - |\mathcal{B}_{II}| + e_2 = \eta([s(T)]_p) - \eta([s(T)]_b)$$

since $|\mathcal{B}_{II}| = 0$ dan $e_2 = 0$ in $[s(T)]_p$. Since all tails of $s(T)$ are even with an order at least two, deleting pendant vertices of every tail does not delete the tail. Thus, the number of tails in every branch in $[s(T)]_p$ is equal to the number of tails in every branch in T . Consequently, by Theorem 4, we have $\dim([s(T)]_p) = \dim(T)$, and the assertion follows.

For the second part, suppose that T has only even tails. Similar to the previous part, all tails of $[T]_p$ are odd, so all branches of $[T]_p$ are of Type I. Hence, by Theorem 5, we have $\dim([T]_p) = \eta([T]_p) - \eta([T]_b)$. Since the number of tails in every branch in $[T]_p$ and in T are equal, then $\dim([T]_p) = \dim(T)$ by Theorem 4, and the assertion follows. \square

Motivated by the observation that $\dim(K_{1,n}) = \eta(K_{1,n})$ for every $n \geq 2$, we are interested in finding the graphs G with $\dim(G) = \eta(G)$. We give the formal statement of this problem in Section 4. For trees, we have the following characterization as a direct consequence of Theorem 5 and 6.

Proposition 1. *Let T be a tree other than a path. Let \mathcal{B}_I and \mathcal{B}_{II} be the sets of Type I and Type II branches in T , respectively. Let e_1 and e_2 be the number of odd and even tails in T , respectively. Then, $\dim(T) = \eta(T)$ if and only if T satisfies one of the following conditions:*

1. $e_1 \geq 1$ and $\eta(T - \mathcal{B}_I) = e_2 - |\mathcal{B}_{II}|$,
2. $e_1 = 0$ and $\eta(T) = \eta([T]_p) - \eta([T]_b)$,
3. $\eta(T) = \eta([s(T)]_p) - \eta([s(T)]_b)$.

A *homeomorphically irreducible tree*, or HIT for short, is a tree with no vertex of degree two. This structure was studied by Harary and Prins. Foregger [12] and Haslegrave [17] used the term *series-reduced tree* to refer to an HIT. The property of an HIT implies that all branches of an HIT T of order at least four are of Type I, and all tails are odd. In fact, every tail in T is of length 1. Thus, deleting all Type I branches in T is the same as deleting all of its pendant and quasipendant vertices. Consequently, by Theorem 5 and Proposition 1, we obtain the following result.

Theorem 7. *Let T be an HIT of order at least 4. Then, $\dim(T) = \eta(T) - \eta(T_0)$ where T_0 is obtained from T by deleting all of its pendant and quasipendant vertices. Consequently, $\dim(T) = \eta(T)$ if and only if $\eta(T_0) = 0$.*

Moreover, it can be verified that for every HIT T of order $n \in [4, 9]$, $T_0 = \emptyset$. Hence, $\dim(T) = \eta(T)$ for every HIT T of order $n \in [4, 9]$.

We end this section by presenting the following theorem that gives a relationship between the metric dimension of a tree and their \mathbf{L} - and \mathbf{D} -spectra.

Theorem 8. *Let T be a tree. Let \mathbf{L} and \mathbf{D} be the Laplacian and distance matrix of T , respectively, and let $m_{\mathbf{L}}^* := \max\{m_{\mathbf{L}}(\mu) : \mu \in \text{spec}_{\mathbf{L}}(G)\}$ and $m_{\mathbf{D}}^* := \max\{m_{\mathbf{D}}(\partial) : \partial \in \text{spec}_{\mathbf{D}}(G)\}$. Then,*

$$m_{\mathbf{L}}^* - \text{ex}(T) + 1 \leq \dim(T) \leq m_{\mathbf{L}}(1) - \text{ex}(T) + q(T)$$

and

$$m_{\mathbf{D}}^* - \text{ex}(T) \leq \dim(T) \leq m_{\mathbf{D}}(-2) - \text{ex}(T) + q(T) + 1.$$

Proof. By Theorems 3 and 1, $\dim(T) = p(T) - \text{ex}(T) = (p(T) - 1) - k + 1 \geq m_{\mathbf{L}}(\mu) - \text{ex}(T) + 1$ for every $\mu \in \text{spec}_{\mathbf{L}}(T)$. Consequently, $\dim(T) \geq m_{\mathbf{L}}^* - \text{ex}(T) + 1$. Furthermore, from Theorem 2, $p(T) - q(T) \leq m_{\mathbf{L}}(1)$. Thus, we obtain

$$\dim(T) = p(T) - \text{ex}(T) = (p(T) - q(T)) - \text{ex}(T) + q(T) \leq m_{\mathbf{L}}(1) - \text{ex}(T) + q(T),$$

hence the first result. Next, by Theorem 3 and Corollary 1, $\dim(T) = p(T) - \text{ex}(T) \geq m_{\mathbf{D}}(\partial) - \text{ex}(T)$ for every $\partial \in \text{spec}_{\mathbf{D}}(T)$. Consequently, $\dim(T) \geq m_{\mathbf{D}}^* - \text{ex}(T)$. Furthermore, from Corollary 2, $p(T) - q(T) - 1 \leq m_{\mathbf{D}}(-2)$. Thus, we obtain

$$\begin{aligned} \dim(T) &= p(T) - \text{ex}(T) \\ &= (p(T) - q(T) - 1) - \text{ex}(T) + q(T) + 1 \\ &\leq m_{\mathbf{D}}(-2) - \text{ex}(T) + q(T) + 1, \end{aligned}$$

hence the second result. □

3. Twin classes, nullity, and the metric dimension of graphs

In this section, we consider a connected graph G containing a twin class as defined in the following paragraphs. We give a lower bound for the metric dimension of a graph in terms of its twin classes and its nullity. First, we recall some definitions related to twin classes of a graph.

Two distinct vertices u and v in a connected graph $G = (V, E)$ are said to be *twins* if $d(u, x) = d(v, x)$ for every $x \in V \setminus \{u, v\}$ [4]. In [2, 19, 24], twin vertices are called *distance similar*. Other than distances, twin vertices may be defined using their neighborhoods. Two distinct vertices u and v are said to be *false twins* if $N_G(u) = N_G(v)$ and *true twins* if $N_G[u] = N_G[v]$. We call two distinct vertices *twins* if they are false twins or true twins. Note that false twins are not adjacent, while true

twins are adjacent. It was proved by Saenpholphat and Zhang [24] that the definitions of twin vertices using distances and neighborhoods are equivalent.

For two vertices $u, v \in V$, we define a relation \equiv on V where $u \equiv v$ if and only if $u = v$ or u, v are twins. It was proved by Hernando et al. [18] and Saenpholphat and Zhang [24] that \equiv is an equivalence relation. Therefore, we may construct a partition $\tau(G)$ of V consisting of equivalence classes over the relation \equiv . We call $\tau(G)$ the *twin partition* of G . These equivalence classes are called *twin classes*. Note that for a twin class to contain twin vertices, it must be of size at least two; otherwise, it contains only a single vertex, which is not a twin vertex by definition.

The concept of twin classes has a role in determining the vertices that must be contained in every resolving set of a graph, and consequently, they give a lower bound to the metric dimension of the graph, as shown in the following results.

Lemma 3 ([24]). *If X is a twin class in a connected graph G with $|X| = p \geq 2$, then every resolving set of G contains at least $p - 1$ vertices in X .*

Corollary 3 ([27]). *If G is a connected graph, then $\dim(G) \geq \sum_{\tau \in \tau(G)} (|\tau| - 1)$.*

Recall that a set $X \subseteq V(G)$ of a graph G is *independent* in G if no two vertices in X are adjacent in G . The following lemma ensures that a twin class may only have one of two forms: independent in G , or independent in \overline{G} . We call a twin class *false* if it is independent in G , and *true* if it is independent in \overline{G} .

Lemma 4 ([18, 24]). *If X is a twin class of a connected graph G , then either X is false or true.*

Before we discuss our main result, we give the following preliminary results. For a matrix \mathbf{A} , $\mathcal{C}(\mathbf{A})$ denotes the *column space* or *range* of \mathbf{A} , that is, the vector space spanned by the columns of \mathbf{A} .

Lemma 5 ([22]). *Let $\mathbf{A} \in \mathbb{C}^{m \times n}$, $\mathbf{B} \in \mathbb{C}^{m \times k}$, $\mathbf{C} \in \mathbb{C}^{l \times n}$, \mathbf{O} be the zero matrix, and $\mathbf{0}$ be the zero vector. Then, the following statements hold:*

1. $\text{rank} \begin{bmatrix} \mathbf{A} & \mathbf{B} \\ \mathbf{C} & \mathbf{O} \end{bmatrix} \leq \text{rank}(\mathbf{A}) + \text{rank}(\mathbf{B}) + \text{rank}(\mathbf{C})$.
2. $\text{rank} \begin{bmatrix} \mathbf{A} & \mathbf{B} \\ \mathbf{C} & \mathbf{O} \end{bmatrix} = \text{rank}(\mathbf{A}) + \text{rank}(\mathbf{B}) + \text{rank}(\mathbf{C})$ if and only if $\mathcal{C}(\mathbf{A}) \cap \mathcal{C}(\mathbf{B}) = \{\mathbf{0}\}$ and $\mathcal{C}(\mathbf{A}^*) \cap \mathcal{C}(\mathbf{C}^*) = \{\mathbf{0}\}$.

Now, we investigate the spectral properties of a twin class of a connected graph, if it exists, and their relation to the metric dimension of the graph. Let G be a connected graph, and $X \subseteq V(G)$ be a twin class in G with $|X| \geq 2$. For the following discussions, we define the sets X_N and X_C (depending on X) as follows. The set X_N is defined as

the common neighborhood of the vertices of X , that is, $X_N := N(v)$ for every $v \in X$, and $X_C := V \setminus (X \cup X_N)$ (see Figure 5).

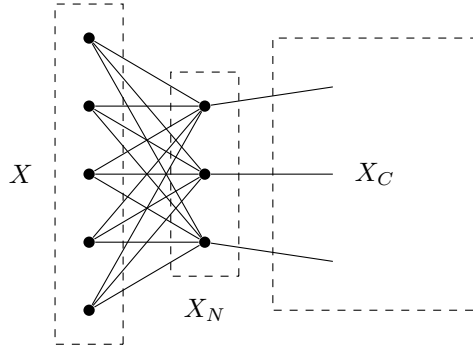

Figure 5. An example of a twin class X and the sets X_N and X_C

By giving the indices to the vertices in X_C , X_N , and X , in this order, we obtain the adjacency matrix \mathbf{A}_G of G as follows:

$$\mathbf{A}_G = \begin{bmatrix} \mathbf{B} & \mathbf{C} & \mathbf{O} \\ \mathbf{C}^* & \mathbf{D} & \mathbf{J} \\ \mathbf{O}^* & \mathbf{J}^* & \mathbf{E} \end{bmatrix} = \begin{bmatrix} \mathbf{A}_{G-X} & \mathbf{P} \\ \mathbf{P}^* & \mathbf{E} \end{bmatrix} \quad (3.1)$$

where \mathbf{O} is the $|X_C| \times |X|$ zero matrix, \mathbf{J} is the $|X_N| \times |X|$ all-ones matrix, and $\mathbf{P} = \begin{bmatrix} \mathbf{O} \\ \mathbf{J} \end{bmatrix}$. This index ordering, which produces the block matrix in Equation 3.1, will be used in the following results. Note that different twin classes may produce different block matrices since the sets X_N and X_C may be different.

The following lemma gives a relation between the nullity of a graph and the nullity of the subgraph obtained by deleting a twin class in the graph. For a positive integer n , we denote by $\mathbf{0}_n$ and $\mathbf{1}_n$ the $n \times 1$ vector, whose entries are all 0 and 1, respectively.

Lemma 6. *Let G be a connected graph and $X \subseteq V(G)$ be a false twin class with $|X| \geq 2$. Then, $\eta(G) \geq \eta(G - X) + |X| - 2$. Furthermore, equality holds if and only if*

$$\mathcal{C}(\mathbf{A}_{G-X}) \cap \mathcal{C} \begin{bmatrix} \mathbf{0}_{|X_C|} \\ \mathbf{1}_{|X_N|} \end{bmatrix} = \{\mathbf{0}_{|X_C|+|X_N|}\} \quad (3.2)$$

where \mathbf{A}_{G-X} is the adjacency matrix of $G - X$ according to Equation 3.1.

Proof. Let \mathbf{A}_G and \mathbf{A}_{G-X} be the adjacency matrix of G and $G - X$, respectively, and let $|V(G)| = n$. Since X is false, every two vertices in X are not adjacent. So, in

Equation 3.1, $\mathbf{E} = \mathbf{O}_{|X|}$ is an $|X| \times |X|$ zero matrix, and we have

$$\mathbf{A}_G = \begin{bmatrix} \mathbf{A}_{G-X} & \mathbf{P} \\ \mathbf{P}^* & \mathbf{O}_{|X|} \end{bmatrix}.$$

Consequently, by Lemma 5 (1), we have

$$\text{rank}(\mathbf{A}_G) \leq \text{rank}(\mathbf{A}_{G-X}) + \text{rank}(\mathbf{P}) + \text{rank}(\mathbf{P}^*) = \text{rank}(\mathbf{A}_{G-X}) + 2$$

since $\text{rank}(\mathbf{P}) = 1$. So, by the well-known rank-nullity theorem, we have

$$\begin{aligned} \eta(G) &= n - \text{rank}(\mathbf{A}) \\ &\geq n - \text{rank}(\mathbf{A}_{G-X}) - 2 \\ &= (n - |X| - \text{rank}(\mathbf{A}_{G-X})) + |X| - 2 \\ &= \eta(G - X) + |X| - 2. \end{aligned}$$

Furthermore, since \mathbf{A} is symmetric, $\mathbf{A}_{G-X} = \mathbf{A}_{G-X}^*$ and $[\mathbf{O} \ \mathbf{J}^*]^* = \begin{bmatrix} \mathbf{O} \\ \mathbf{J} \end{bmatrix}$. Additionally, observe that $\mathcal{C} \begin{bmatrix} \mathbf{O} \\ \mathbf{J} \end{bmatrix} = \mathcal{C} \begin{bmatrix} \mathbf{0}_{|X_C|} \\ \mathbf{1}_{|X_N|} \end{bmatrix}$. Consequently, by Lemma 5 (2), the equality holds if and only if $\mathcal{C}(\mathbf{A}_{G-X}) \cap \mathcal{C} \begin{bmatrix} \mathbf{O} \\ \mathbf{J} \end{bmatrix} = \mathcal{C}(\mathbf{A}_{G-X}) \cap \mathcal{C} \begin{bmatrix} \mathbf{0}_{|X_C|} \\ \mathbf{1}_{|X_N|} \end{bmatrix} = \{\mathbf{0}_{|X_C|+|X_N|}\}$. \square

Remark 1. To prove the condition $\mathcal{C}(\mathbf{A}_{G-X}) \cap \mathcal{C} \begin{bmatrix} \mathbf{0}_{|X_C|} \\ \mathbf{1}_{|X_N|} \end{bmatrix} = \{\mathbf{0}_{|X_C|+|X_N|}\}$, it is sufficient to show that $\mathcal{C}(\mathbf{A}_{G-X}) \cap \mathcal{C} \begin{bmatrix} \mathbf{0}_{|X_C|} \\ \mathbf{1}_{|X_N|} \end{bmatrix} \subseteq \{\mathbf{0}_{|X_C|+|X_N|}\}$, which is equivalent to show that:

$$\text{if } \alpha \begin{bmatrix} \mathbf{0}_{|X_C|} \\ \mathbf{1}_{|X_N|} \end{bmatrix} \in \mathcal{C}(\mathbf{A}_{G-X}) \text{ for some } \alpha \in \mathbb{C}, \text{ then } \alpha = 0.$$

The following observation gives some sufficient conditions for a false twin class X to satisfy Equation 3.2. We formally state the general problem in Section 4.

Observation 9. Let G be a connected graph and X be a false twin class in G with $|X| \geq 2$. Then, the Equation 3.2 holds if one of the following conditions holds:

1. there exists $u \in X_N$ such that $N_G(u) = X$,
2. there exist $u \in X_N$ and $v \in X_C$ such that $N_{G-X}(u) = N_{G-X}(v)$.

Proof. Let $\mathbf{x} = (0, \dots, 0, \alpha, \dots, \alpha) \in \mathcal{C}(\mathbf{A}_{G-X})$ with $|X_C|$ 0's and $|X_N|$ α 's for some $\alpha \in \mathbb{C}$, so there exists \mathbf{y} such that $\mathbf{A}_{G-X}\mathbf{y} = \mathbf{x}$. By Remark 1, it is sufficient to show that $\alpha = 0$. For a vector \mathbf{x} , we denote the i th entry of \mathbf{x} by $[\mathbf{x}]_i$. First, we assume that

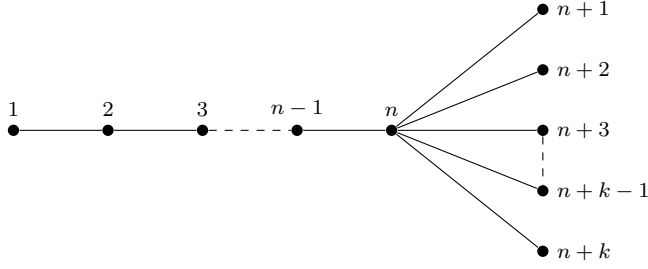

Figure 6. The graph G that satisfies the equality in Lemma 6 (when n is odd)

condition 1 holds. This means that u is an isolated vertex in $G - X$, so the u th row of \mathbf{A}_{G-X} contains only zero entries. Since $u \in X_N$, $\alpha = [\mathbf{x}]_u = [\mathbf{A}_{G-X}\mathbf{y}]_u = 0$. Next, we assume that condition 2 holds. This means that the u th row and the v th row of \mathbf{A}_{G-X} are identical, hence $[\mathbf{A}_{G-X}\mathbf{y}]_u = [\mathbf{A}_{G-X}\mathbf{y}]_v$. Since $u \in X_N$ and $v \in X_C$, we have $\alpha = [\mathbf{x}]_u = [\mathbf{A}_{G-X}\mathbf{y}]_u = [\mathbf{A}_{G-X}\mathbf{y}]_v = [\mathbf{x}]_v = 0$. \square

As noted earlier, there are some possible conditions of a false twin class X satisfying Equation 3.2 other than those mentioned in Observation 9. One of the examples is the following.

Example 4. Consider the graph G shown in Figure 6 with an odd n and any $k \geq 2$. Observe that $X = \{n+i : i \in [1, k]\} \subseteq V(G)$ is a false twin class with $|X| = k \geq 2$. We will prove that $\eta(G) = \eta(G - X) + |X| - 2$ by showing that Equation 3.2 holds. From the twin class X , we obtain $X_N = \{n\}$ and $X_C = [1, n-1]$. Thus, the vector $\begin{bmatrix} \mathbf{0}_{|X_C|} \\ \mathbf{1}_{|X_N|} \end{bmatrix}$ in this case is $(0, 0, \dots, 0, 1)^* \in \mathbb{C}^n$. Observe that $G - X = P_{n-1}$ with adjacency matrix

$$\mathbf{A}_{G-X} = \begin{bmatrix} 0 & 1 & 0 & 0 & \cdots & 0 & 0 & 0 & 0 \\ 1 & 0 & 1 & 0 & \cdots & 0 & 0 & 0 & 0 \\ 0 & 1 & 0 & 1 & \cdots & 0 & 0 & 0 & 0 \\ \vdots & \vdots & \vdots & \vdots & & \vdots & \vdots & \vdots & \vdots \\ 0 & 0 & 0 & 0 & \cdots & 1 & 0 & 1 & 0 \\ 0 & 0 & 0 & 0 & \cdots & 0 & 1 & 0 & 1 \\ 0 & 0 & 0 & 0 & \cdots & 0 & 0 & 1 & 0 \end{bmatrix}.$$

We show that $\mathcal{C}(\mathbf{A}_{G-X}) \cap \mathcal{C}((0, 0, \dots, 0, 1)^*) = \{\mathbf{0}_n\}$. By Remark 1, it is sufficient to show that if $(0, 0, \dots, 0, \alpha)^* \in \mathcal{C}(\mathbf{A}_{G-X})$ for some $\alpha \in \mathbb{C}$, then $\alpha = 0$. Now, let $(0, 0, \dots, 0, \alpha)^* \in \mathcal{C}(\mathbf{A}_{G-X})$ for some $\alpha \in \mathbb{C}$, so there exists $\mathbf{y} = (y_1, y_2, \dots, y_n)^*$ such that $\mathbf{A}_{G-X}\mathbf{y} = (0, 0, \dots, 0, \alpha)$. So, we obtain the following equations (by considering only the odd rows of \mathbf{A}_{G-X}):

$$y_2 = 0, \quad y_2 + y_4 = 0, \quad y_4 + y_6 = 0, \quad \dots, \quad y_{n-3} + y_{n-1} = 0, \quad \text{and} \quad y_{n-1} = \alpha,$$

which imply $\alpha = 0$. Thus, Equation 3.2 holds, and by Lemma 6, $\eta(G) = \eta(G - X) + |X| - 2$.

Theorem 10. *Let G be a connected graph, $\tau(G)$ be the twin partition of G , and*

$$\mathcal{X} = \left\{ X \in \tau(G) : |X| \geq 2, X \text{ is false}, \mathcal{C}(\mathbf{A}_{G-X}) \cap \mathcal{C} \begin{bmatrix} \mathbf{0}_{|X_C|} \\ \mathbf{1}_{|X_N|} \end{bmatrix} = \{\mathbf{0}_{|X_C|+|X_N|}\} \right\}$$

where \mathbf{A}_{G-X} is the adjacency matrix of $G - X$ according to Equation 3.1. Then,

$$\dim(G) \geq |\mathcal{X}|(\eta(G) + 1) - \sum_{X \in \mathcal{X}} \eta(G - X).$$

Proof. Let $X \in \mathcal{X}$ be arbitrary. Assume that the hypotheses are true, so by Lemma 6, we have $|X| = \eta(G) + 2 - \eta(G - X)$. Hence, by Lemma 3,

$$\dim(G) \geq \sum_{X \in \mathcal{X}} (|X| - 1) = |\mathcal{X}|(\eta(G) + 1) - \sum_{X \in \mathcal{X}} \eta(G - X).$$

Therefore, the proof is complete. \square

The bound in Theorem 10 is sharp, as shown in the following example.

Example 5. Consider the complete bipartite graph $G = K_{m,n}$ with partitions V_1 and V_2 where $|V_1| = m$, $|V_2| = n$, and $m > n \geq 2$. It is well known that $\dim(G) = m + n - 2$ and $\eta(G) = m + n - 2$. Now, observe that the twin partition of G is $\tau(G) = \{V_1, V_2\}$. Since for each $X \in \tau(G)$, there exists $u \in X_N = \tau(G) \setminus X$ such that $N_G(u) = X$, so Equation 3.2 holds by Observation 9 (1). Therefore, $\mathcal{X} = \tau(G)$. Now, observe that $G - V_1 = \overline{K_n}$ and $G - V_2 = \overline{K_m}$. Thus,

$$\begin{aligned} |\mathcal{X}|(\eta(G) + 1) - \sum_{X \in \mathcal{X}} \eta(G - X) &= (2)(m + n - 2 + 1) - (\eta(\overline{K_m}) + \eta(\overline{K_n})) \\ &= 2(m + n - 1) - (m + n) \\ &= m + n - 2. \end{aligned}$$

Therefore, $\dim(G) = |\mathcal{X}|(\eta(G) + 1) - \sum_{X \in \mathcal{X}} \eta(G - X)$.

Example 6. Recall the graph G in Figure 6 with twin class $X = \{n + i : i \in [1, k]\}$. It is clear that X is the only twin class of G that satisfies the hypotheses of Theorem 10, as we have shown in Example 4, so $\mathcal{X} = \{X\}$. Observe that $\eta(G) = k - 1$ and $\eta(G - X) = 1$, so by Theorem 10, we have

$$\dim(G) \geq |\mathcal{X}|(\eta(G) + 1) - \sum_{X \in \mathcal{X}} \eta(G - X) = (1)(k - 1 + 1) - 1 = k - 1.$$

Note that the exact value of the metric dimension of G is $\dim(G) = k$.

4. Some open problems

In this section, we propose some open problems related to our results. Our first problem is the characterization of a graph G whose metric dimension and nullity are equal. This will be very helpful since the calculation of the metric dimension of a graph, which is NP-complete in general, is reduced to the calculation of its nullity. Before we state our problem formally, let us recall the following definition. Let G and H be graphs, where $V(G) = \{v_1, v_2, \dots, v_n\}$. The *corona product* $G \odot H$ is the graph obtained by taking one copy of G and n copies of H and then joining by an edge every vertex from the i th copy of H to v_i .

Problem 1. Characterize graphs G satisfying $\dim(G) = \eta(G)$.

As we have mentioned before, some solutions for this problem are as follows:

1. $G = K_{1,n}$ for $n \geq 1$,
2. G is an HIT of order $n \in [3, 9]$,
3. G is a tree satisfying one of the conditions in Proposition 1, and
4. $G = H \odot \overline{K_m}$ for any connected graph H and integer $m \geq 2$.

The reader may verify the fourth solution. First, it was proved by Iswadi, Baskoro, Simanjuntak, and Salman [19] that if H is a connected graph of order n and $m \geq 2$, then $\dim(H \odot \overline{K_m}) = n(m - 1)$. Furthermore, it is easy to verify, using Lemma 1, that $\eta(H \odot \overline{K_m}) = n(m - 1)$. Hence, $\dim(H \odot \overline{K_m}) = \eta(H \odot \overline{K_m})$.

In Proposition 1, we have given an algebraic characterization for a tree T to satisfy $\dim(T) = \eta(T)$. However, we are interested in finding the graph-structural properties of a tree that satisfy these algebraic conditions. Hence, the following problem is formulated.

Problem 2. Find the graph-structural properties of a tree T satisfying one of the three conditions in Proposition 1.

Next, let us recall the hypotheses of Theorem 10, specifically Equation 3.2. As before, we are interested in the graph-structural properties of a false twin class X in a graph G satisfying Equation 3.2. We formally state the problem as follows.

Problem 3. Find the graph-structural properties of a false twin class X satisfying Equation 3.2.

We have shown that the graph G and twin class X in Example 4 (Figure 6) satisfy Equation 3.2. We have also proved Observation 9 as a partial solution to this problem.

Recall that the twin classes considered in Lemma 6, Observation 9, and Theorem 10 are false twin classes. However, the cases for true twin classes have not been investigated yet; hence, the following problem is formulated.

Problem 4. Investigate the spectral properties of true twin classes and their relation to the metric dimension of a graph.

Finally, recall that Theorem 8 uses the distance matrix to approximate the metric dimension of a tree. Since the metric dimension of a graph is a distance-based concept and distance matrix contains information on the distances in the graph, it is natural to conjecture that there are relations between the properties of the distance matrix of a graph and its metric dimension; hence, the following problem is posed.

Problem 5. Find another relationship between the distance matrix of a graph and its metric dimension.

5. Conclusion

In this paper, we have initiated research on the relation between the metric dimension of a graph and its spectral properties. We have found a relation between the metric dimension of a tree other than a path and its nullity (Theorems 5 and 6), a relation between the metric dimension of a tree and its **L**- and **D**-spectra (Theorem 8), and a lower bound for the metric dimension of a general graph in terms of its twin classes and its nullity (Theorem 10). Additionally, we have proposed a few open problems that could serve as subjects for future study.

Acknowledgement: The authors are thankful to the referees for their comments that helped to improve the presentation of the manuscript. This research has been supported by Penelitian Fundamental Reguler, Ministry of Education, Culture, Research, and Technology, Republic of Indonesia

Conflict of Interest: The authors declare that they have no conflict of interest.

Data Availability: Data sharing is not applicable to this article as no datasets were generated or analyzed during the current study.

References

- [1] S. Akhter and R. Farooq, *Metric dimension of fullerene graphs*, Electron. J. Graph Theory Appl. **7** (2019), no. 1, 91–103.
<https://doi.org/10.5614/ejgta.2019.7.1.7>.

-
- [2] S. Arumugam and R.A. Kumar, *Distance similar sets in graphs*, Util. Math. **102** (2017), 265–281.
- [3] R.B. Bapat, *Graphs and Matrices*, Springer, London, 2010.
- [4] E.T. Baskoro, *Dimensi dalam Graf*, ITB Press, Bandung, 2023.
- [5] N. Biggs, *Algebraic Graph Theory*, Cambridge University Press, Cambridge, 1993.
- [6] G. Chartrand, L. Eroh, M.A. Johnson, and O.R. Oellermann, *Resolvability in graphs and the metric dimension of a graph*, Discrete Appl. Math. **105** (2000), no. 1–3, 99–113.
[https://doi.org/10.1016/S0166-218X\(00\)00198-0](https://doi.org/10.1016/S0166-218X(00)00198-0).
- [7] R. Chen, S. Fazal, A. Aslam, F. Tchier, and M.A. Binyamin, *On the metric dimension of graphs associated with irreducible and Arf numerical semigroups*, AKCE Int. J. Graphs Comb. (2024), In press.
<https://doi.org/10.1080/09728600.2024.2350582>.
- [8] D. Cvetković, P. Rowlinson, and S. Simić, *An Introduction to the Theory of Graph Spectra*, Cambridge University Press, Cambridge, 2010.
- [9] D.M. Cvetković and I. Gutman, *The algebraic multiplicity of the number zero in the spectrum of a bipartite graph*, Mat. Vesn. **9** (1972), no. 56, 141–150.
- [10] R. Diestel, *Graph Theory*, Springer, Berlin, 2017.
- [11] I. Faria, *Permanental roots and the star degree of a graph*, Linear Algebra Appl. **64** (1985), 255–265.
[https://doi.org/10.1016/0024-3795\(85\)90281-2](https://doi.org/10.1016/0024-3795(85)90281-2).
- [12] T.H. Foregger, *Identities related to permanents of doubly stochastic matrices and series reduces trees*, Linear Multilinear Algebra **7** (1979), no. 1, 37–41.
<https://doi.org/10.1080/03081087908817257>.
- [13] M.R. Garey and D.S. Johnson, *Computers and Intractability: A Guide to the Theory of NP-Completeness*, W.H. Freeman and Company, New York, 1979.
- [14] R. Grone, R. Merris, and V.S. Sunder, *The Laplacian spectrum of a graph*, SIAM J. Matrix Anal. Appl. **11** (1990), no. 2, 218–238
<https://doi.org/10.1016/j.camwa.2004.05.005>.
- [15] I. Gutman and B. Borovicanin, *Nullity of graphs: an updated survey*, Zbornik Radova **14** (2011), no. 22, 137–154.
- [16] F. Harary and R.A. Melter, *On the metric dimension of a graph*, Ars Combin. **2** (1976), 191–195.
- [17] J. Haslegrave, *Extremal results on average subtree density of series-reduced trees*, J. Combin. Theory Ser. B **107** (2014), 26–41.
<https://doi.org/10.1016/j.jctb.2014.02.003>.
- [18] C. Hernando, M. Mora, I.M. Pelayo, C. Seara, and D.R. Wood, *Extremal graph theory for metric dimension and diameter.*, Electron. J. Comb. **17** (2010), no. 1, Article number: R30
<https://doi.org/10.37236/302>.
- [19] H. Iswadi, E.T. Baskoro, R. Simanjuntak, and A.N.M. Salman, *The metric dimension of graph with pendant edges*, J. Comb. Math. Comb. Comput. **65** (2008), 139–145.
- [20] S. Khuller, B. Raghavachari, and A. Rosenfeld, *Landmarks in graphs*, Discrete

- Appl. Math. **70** (1996), no. 3, 217–229.
[https://doi.org/10.1016/0166-218X\(95\)00106-2](https://doi.org/10.1016/0166-218X(95)00106-2).
- [21] D. Kuziak and I.G. Yero, *Metric dimension related parameters in graphs: A survey on combinatorial, computational and applied results*, arXiv:2107.04877 (2021).
- [22] G. Matsaglia and G. PH Styan, *Equalities and inequalities for ranks of matrices*, Linear Multilinear Algebra **2** (1974), no. 3, 269–292.
<https://doi.org/10.1080/03081087408817070>.
- [23] R. Merris, *The distance spectrum of a tree*, J. Graph Theory **14** (1990), no. 3, 365–369.
<https://doi.org/10.1002/jgt.3190140309>.
- [24] V. Saenpholphat and P. Zhang, *Some results on connected resolvability in graphs*, Congr. Numer. **158** (2002), 5–20.
- [25] S.K. Sharma, V.K. Bhat, and P. Singh, *On metric dimension of some planar graphs with $2n$ odd sided faces*, Discrete Math. Algorithms Appl. **16** (2024), no. 1, Article ID: 2250185.
<https://doi.org/10.1142/S1793830922501853>.
- [26] P.J. Slater, *Leaves of trees*, Congr. Numer. **14** (1975), 549–559.
- [27] R.C. Tillquist, R.M. Frongillo, and M.E. Lladser, *Getting the lay of the land in discrete space: A survey of metric dimension and its applications*, SIAM Rev. **65** (2023), no. 4, 919–962.
<https://doi.org/10.1137/21M1409512>.